

# BOUNCE *FORWARD*

*BUILDING THRIVING, HEALTHY, &  
EQUITABLE COMMUNITIES*



**MARCH**  
4 & 5, 12, 19, 25 & 26



# RMLUI 2021

WESTERN PLACES | WESTERN SPACES



BABBITT CENTER  
FOR LAND AND WATER POLICY

*A Center of the Lincoln Institute of Land Policy*



CLARION





**RMLUI 2021**  
*WESTERN PLACES | WESTERN SPACES*



---

# **GARY COMMUNITY INVESTMENTS**

Working together  
for Colorado's children





**RMLUI 2021**  
*WESTERN PLACES | WESTERN SPACES*



**Brian Connolly**

Otten Johnson Robinson Neff + Ragonetti





**RMLUI 2021**  
WESTERN PLACES | WESTERN SPACES



**Ahmad Abu-Khalaf**, Senior Research Analyst, Enterprise Community Partner  
**Renee Martinez Stone**, Director, West Denver Renaissance Collaborative  
**Councilwoman Amanda Sandoval**, Denver City Council





# Bringing ADU Development to Scale

Ahmad Abu-Khalaf, Senior Research Analyst,  
Enterprise Community Partners

Thursday, March 25, 2021

# ADU DEVELOPMENT & GENTLE DENSITY

Accessory dwelling unit (ADU) is a broad term that refers to a smaller, self-contained residential dwelling that is located on the same parcel as a primary, larger residential dwelling, typically a single-family home

ADU development is the low end of the gentle density (missing middle housing) spectrum. Permitting ADU development in single-family zoned areas is the first step toward supporting gentle density

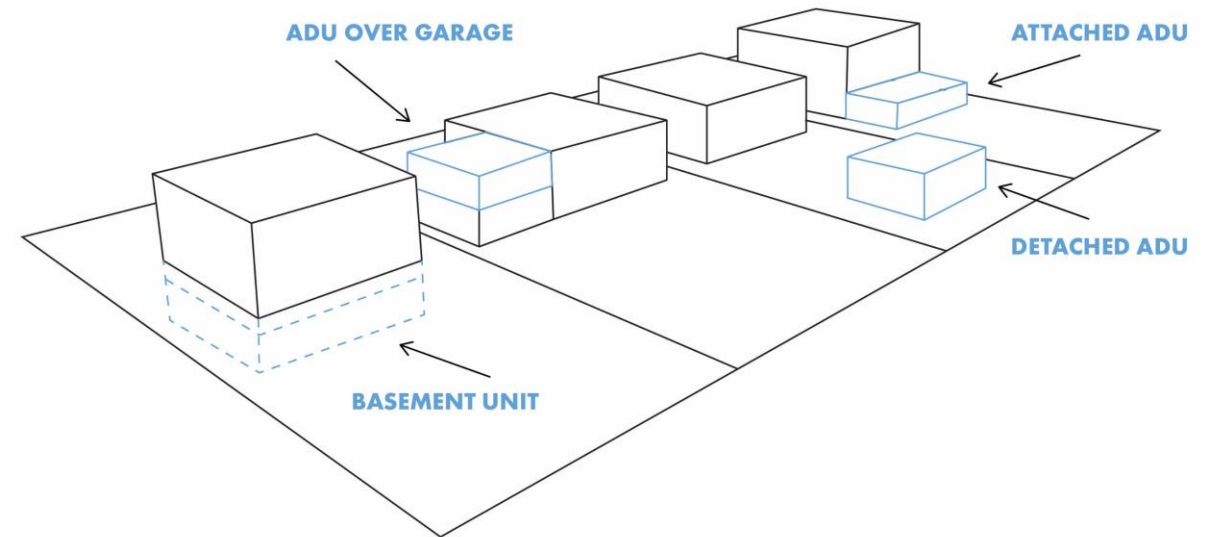





# POLICY GOALS

- Allowing for ADU development typically requires a low regulatory lift that does not induce heavy local opposition
- Permitting rental ADUs can boost the diversity of housing types in single-family zoned areas
- ADU development can support aging in place and multigenerational housing strategies
- Rental ADUs can be utilized to generate additional income and build wealth for low- and moderate-income homeowners

# REGULATORY BARRIERS TO ADU DEVELOPMENT

- At a minimum, municipal governments must permit ADU development in some/all single-family zones to support ADU development
- In many jurisdictions where ADU development is permitted, there are zoning provisions that can create regulatory barriers to ADU development
- These regulatory barriers can result in complex, lengthy permitting processes; reduce the feasibility of creating ADUs; and discourage homeowners from pursuing ADU development





# REGULATORY BARRIERS TO ADU DEVELOPMENT

- Discretionary review processes
- Owner-occupancy requirements
- Off-street parking requirements
- Minimum lot size requirements and large setbacks

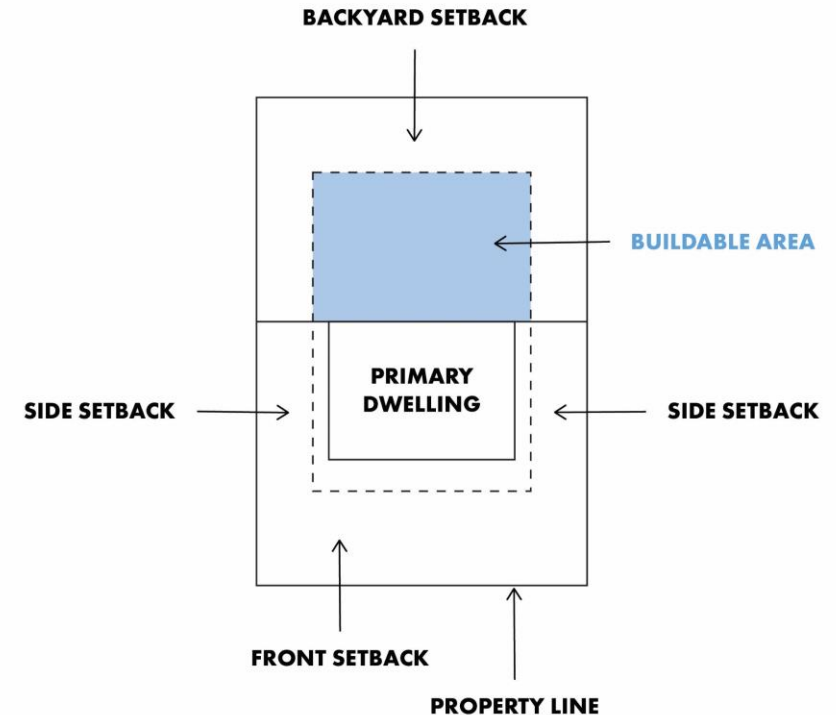



# REGULATORY BARRIERS TO ADU DEVELOPMENT

- Restrictive size and height caps
- Prescriptive design standards
- Impact fees and utility connections cost burdens

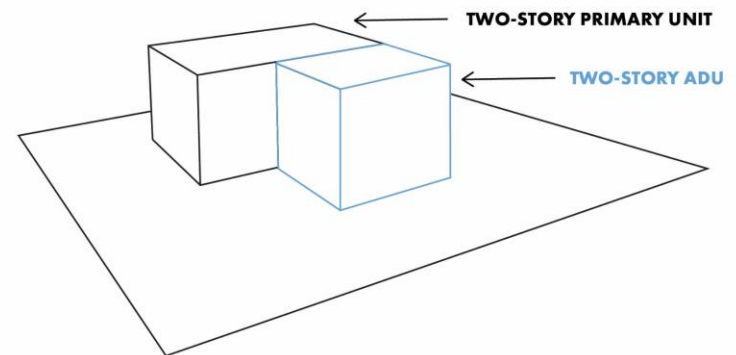
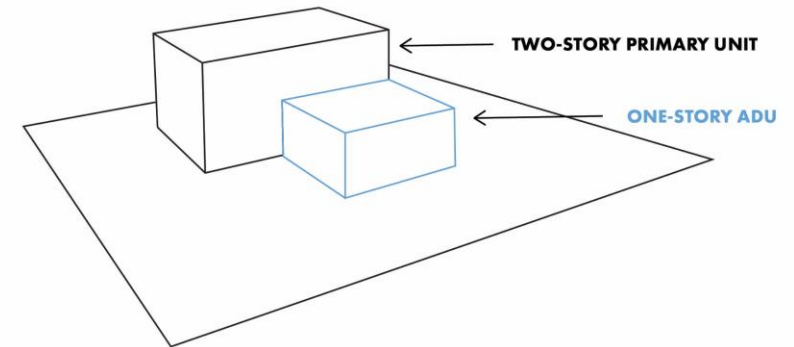

# BARRIERS TO FINANCING ADU DEVELOPMENT

- There are persisting barriers to financing ADU development, especially for lower- and moderate-income homeowners
- The scarcity of lending products tailored for ADU financing has made tapping into homeowners' cash savings or home equity the most common path for financing ADU development
- Lower- and moderate-income homeowners are less likely to be able to use these financing mechanisms. In addition, there are challenges in using these lending products to finance ADU development



# OVERCOMING BARRIERS TO FINANCING ADU DEVELOPMENT

Federal agencies that back mortgages and private lenders can explore creating lending products tailored for ADU development. These products would:

- Enable low- and moderate-income homeowners to finance and develop ADUs on their lots
- Offer favorable loan terms and interest rates
- Include the projected rental income from the ADU in calculating the Debt-To-Income ratio and appraised value
- Provide for a loan underwriting process tailored for the population in need of ADU financing

Federal, state and local agencies, as well as private and philanthropic partners can also support ADU development through offering financial support to low- and moderate-income homeowners





**For additional information:**

**Website:**  
**[bit.ly/PDR\\_Reports](https://bit.ly/PDR_Reports)**

**Email:**  
**[aabukhalaf@enterprisecommunity.org](mailto:aabukhalaf@enterprisecommunity.org)**





## Mission

The mission of the West Denver Renaissance Collaborative (WDRC) is to facilitate the revitalization of West Denver in an equitable fashion improving the livelihood of existing residents' and working to preserve and amplify the rich multicultural character.

March 2021

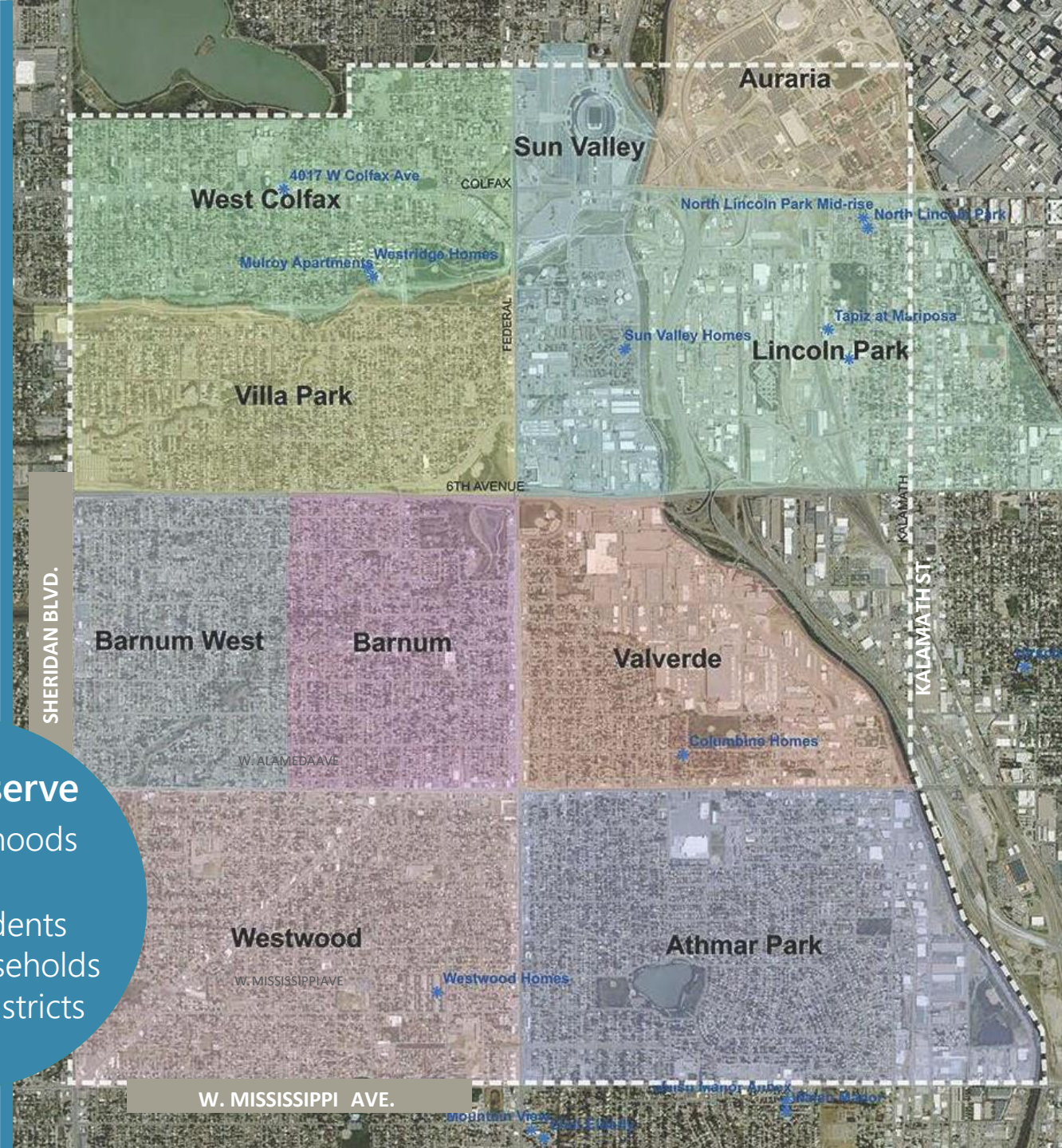

## Who we serve

- 9 neighborhoods
- 6400 acres
- 65,000 residents
- 25,000 households
- 3 Council districts





# Displacement in west Denver (pre COVID-19)

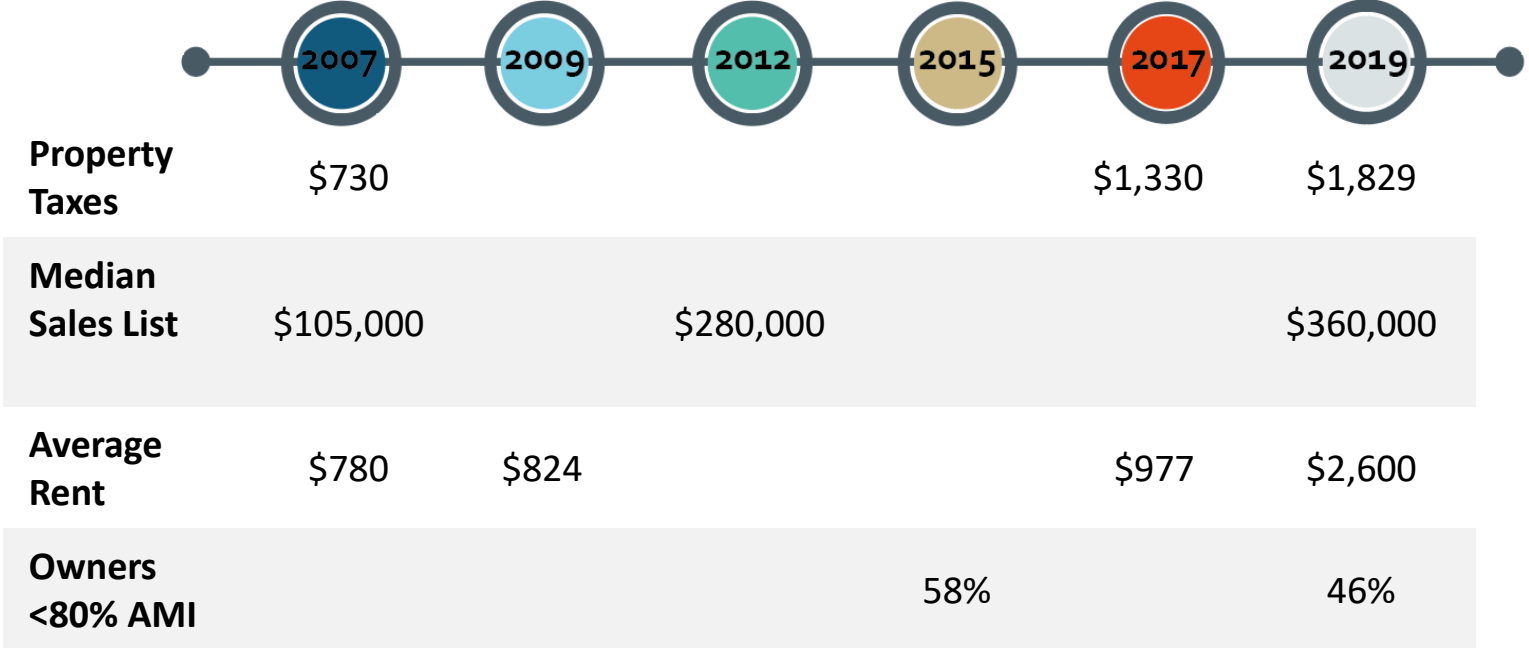

2015-2018 there were 3,900 low income households displaced, including 5,800 kids below age of 18

20K Households (83%) Vulnerable\* or Experiencing Gentrification\*\*

\*Tracts with the majority of households earning <60% AMI \*\*Tracts that were vulnerable in the base year and experienced both: above average increase in educational attainment and above average increase in either median rent, or median value

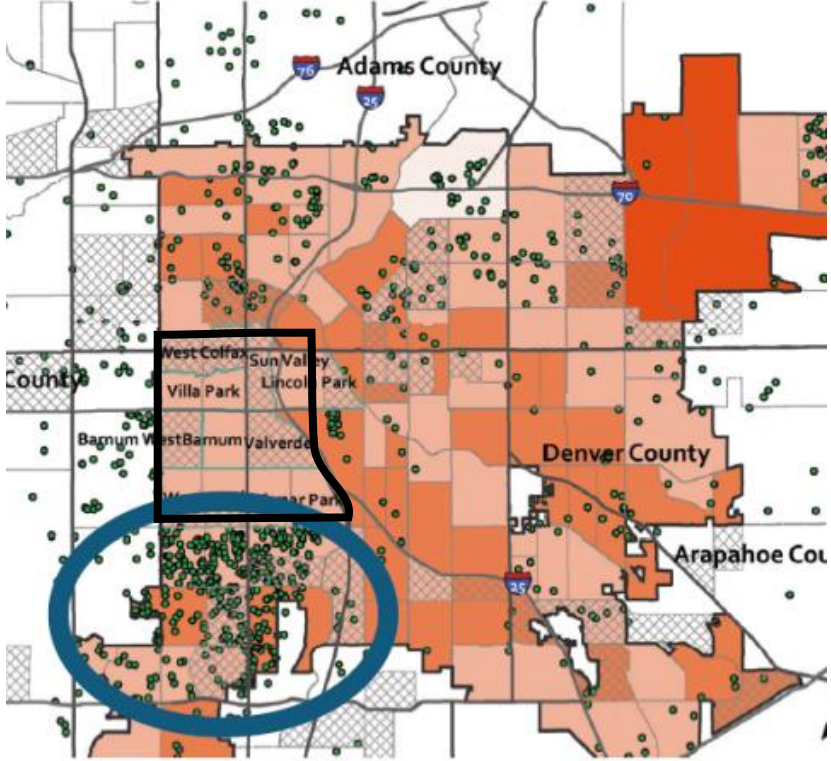

Where displaced families went around Denver metro?



# WDSF+ ADU Pilot Program

## Goals

1. Stabilize Homeowners to minimize involuntary displacement
2. Provide wealth building opportunity
3. Create new long term affordable units
4. Promote equitable access to ADU zoning & development

## Partners & Funders

Denver Housing Authority (DHA), Habitat for Humanity Metro Denver, Fannie Mae, First Bank, City and County of Denver (HOST, NEST, CPD), SPARCC (Mile High Connects, Enterprise Community Partners), Colorado Housing & Finance Authority (CHFA)



# Program Services

- Outreach & Education
- Qualification & project feasibility
- Custom housing counseling
- Connection to ADU lending/financing options
- Project cost-estimating
- Site predevelopment services/bridge costs
- Design & Engineering
- Permitting with the City
- ADU construction
- Property management training





# ADU Benefits

- Add living space for family
- Stay in place w/ADU and primary home
- Economic resilience with an income generating asset
- Build/stabilize inter-generational wealth
- **Provide affordable rental housing in scale & character with neighborhood**
- Help prevent displacement
- Activate alleys



*Having the option of building an ADU can provide homeowners the ability to stay, invest, generate income and to further grow their home equity over time.*









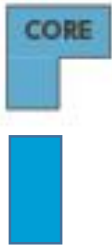

# WDSF+ ADU Pilot Program

## Design

- Quality Design
- 7 Models pre-designed and pre-reviewed by the City
- Designed with input from AIA housing subcommittee and area ADU Builders
- Hybrid construction: manufactured core and built on site

## Costs

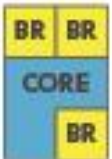
Estimated prices included site costs, construction, materials, professional fees and predevelopment soft costs. Average estimated site specific costs \$25,000, but vary by site (tree removal, sidewalks, etc).

	CORE + BEDROOMS							
Studio	1 Bedroom	2 Bedroom	3 Bedroom					
		<table border="1"> <tr> <td>SMALL</td> <td>LARGE</td> </tr> <tr> <td></td> <td></td> </tr> </table>	SMALL	LARGE				
SMALL	LARGE							
								
432 SF	576 SF	864 SF	864 SF					
\$121,000	\$140,000	\$142,000	\$172,000					
to	to	To	To					
\$168,000	\$186,000	\$216,000	\$218,000					

AT GRADE  
or above  
new garage

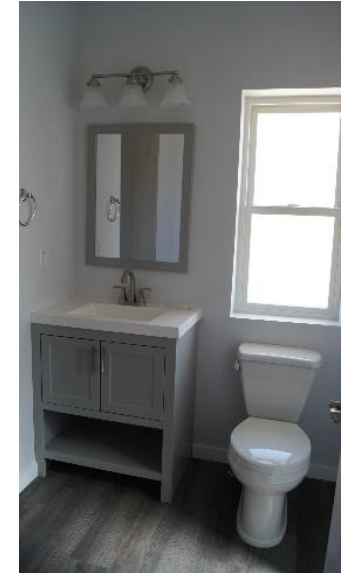

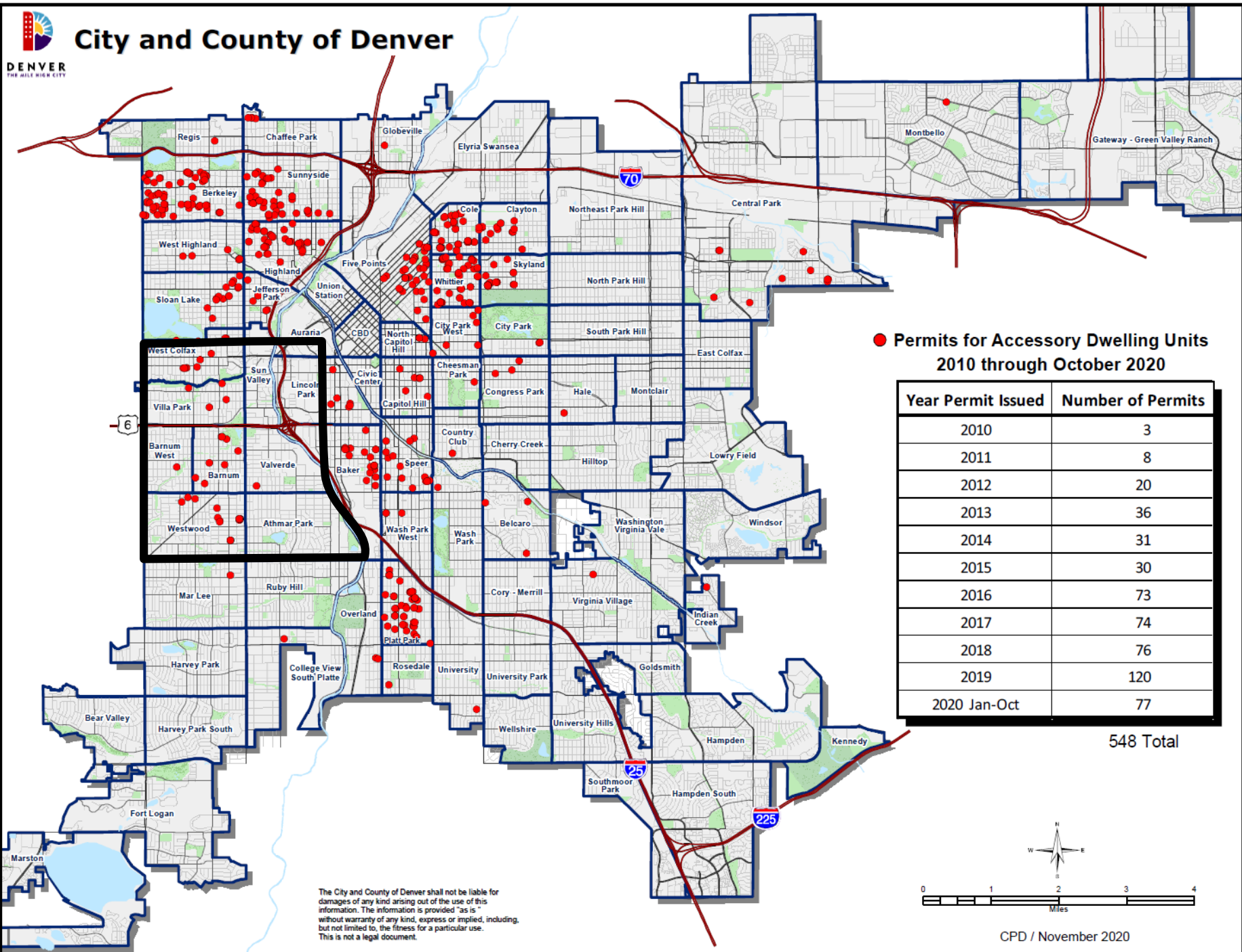

● Permits for Accessory Dwelling Units  
2010 through October 2020

Year Permit Issued	Number of Permits
2010	3
2011	8
2012	20
2013	36
2014	31
2015	30
2016	73
2017	74
2018	76
2019	120
2020 Jan-Oct	77

548 Total

The City and County of Denver shall not be liable for damages of any kind arising out of the use of this information. The information is provided "as is" without warranty of any kind, express or implied, including, but not limited to, the fitness for a particular use. This is not a legal document.

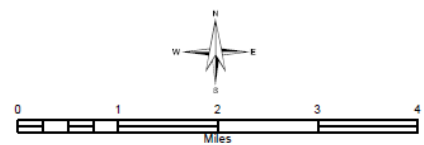



# Barriers for ADUs

1. ADUs as an impactful housing tool – making the case
2. Competing needs & priorities for housing/development review
3. History and systems that result in barriers and ‘inherited geographies’
4. Policy/systems for current issues: stay in place, displacement, a broader range of affordable/restricted options
  - More zoning & overly complex design standards – increases cost
  - Development fee differentiation – small/infill development less feasible
  - Tools & resources for equitable access - barriers for most
5. Impacts of 2020 – cut hours, loan criteria, uncertainty
6. ADU misperceptions / technical support
7. Community asking for local solutions, seeking zoning
  - knowledge/trust, connections, time, cash and/or access to financing

# Visit MyWDRC.org for more info

## 1 Fill out the ADU readiness checklist

**WDSF+ INITIATIVE** ADU READINESS CHECKLIST  
WEST DENVER SINGLE FAMILY PLUS INITIATIVE ACCESSORY DWELLING UNIT (ADU) PILOT PROGRAM

GENERAL ADU READINESS CHECKLIST

This checklist is a brief review of the initial items needed to prepare for building an ADU and applying for financing in general. Once you have completed both sheets, you are ready to apply for the ADU Pilot Program!

**ADU SITE PREPARATION**

- Have you had any recent utility upgrades on the property (new sewer, new water line)?
- Do you have any unpermitted structures (sheds, garages etc.. built without a city permit)?
- Do you know where your property lines are (recent survey)?
- If you know where your property line is, are any sheds, or fences located outside of your property? If so, do you have drawings or plans for these structures?
- What other structures are on the property and what is the total square footage of all structures (sheds, porch, house, gazebo etc..)?
- Do you have an alley, and if not do you have access to the back of your property from the front?
- Is your property located on a corner lot?

**ADU FINANCIAL PREPARATION**

- Is the property in your name?
- Do you know what liens or debts are on your home? (DURA, Solar, etc..)
- Have I co-signed on any loans?
- Do you know the terms of your existing mortgage?
- Calculate or estimate how much equity you have in your home (Loan to Value)
- Find out what your credit score is
- Prepare to work with a lender by collecting the following documents:
  - Two most recent federal tax returns (and W2s if applicable)
  - Two most recent income records (paystubs, bank statements etc..)
  - Current mortgage statement
  - Copy of driver's license or other picture ID

www.mywdrcc.org  
WDSF+ Materials © 2019 WDRCC - All Rights Reserved

## 2 Read more about the program and ask questions

**WDSF+ INITIATIVE**  
ACCESSORY DWELLING UNIT (ADU) PILOT PROGRAM

WDSF+ ADU PILOT PROGRAM INTRODUCTION  
November 2018

The West Denver Single Family Plus (WDSF+) ADU Pilot Program provides mid and low income qualified homeowners design-permit-finance-build services to develop a detached ADU or tandem house.

**WDSF+ INITIATIVE**  
ACCESSORY DWELLING UNIT  
**ADU**  
PILOT PROGRAM

The WDSF+ ADU Pilot Program is currently accepting homeowner applications. Participants must own a home in a West Denver Renaissance Collaborative (WDRCC) neighborhood, income qualify, and have ADU /tandem house zoning. Please review the 'WDSF+ ADU Pilot Program Basic Requirements' to determine your eligibility and interest.

**WDRCC NEIGHBORHOODS**



West Denver Renaissance Collaborative  
777 Grant Street | Denver, CO | 80203 | 720.932.3136

## 3 Complete a Pre-Qualification Application!

**WDSF+ INITIATIVE** PRE-QUALIFICATION APPLICATION  
ACCESSORY DWELLING UNIT (ADU) PILOT PROGRAM  
November 2018

The WDSF+ ADU Pilot Program Pre-Qualification Application is intended for interested homeowners who meet the 'ADU Pilot Program Basic Requirements' listed in the WDSF+ ADU Pilot Program Introduction, which should be reviewed prior to beginning this Pre-Qualification Application. The WDSF+ ADU Pilot Program Introduction can be accessed at [mywdrcc.org/ADUPilotProgramIntroduction](http://mywdrcc.org/ADUPilotProgramIntroduction), or contact WDRCC to request a print copy.

**APPLICANT INFORMATION**

FULL NAME:

APPLICATION PROPERTY ADDRESS: CITY: STATE: ZIP:

PHONE NUMBER: EMAIL: PREFERRED CONTACT METHOD:  PHONE  EMAIL

**ABOUT THE ADU PILOT PROGRAM AND PRE-QUALIFICATION APPLICATION**

Accessory Dwelling Units (ADUs), also known as mother-in-law quarters, in-law suites, casitas, or backyard cottages, have been included in the City and County of Denver Zoning Code since 2010. However, design, permit, financing, and construction barriers have limited ADU development. To improve access to ADU development, the West Denver Single Family Plus (WDSF+) ADU Pilot Program provides design-finance-build services for qualified homeowners and offers significant cost savings compared to the market rate ADU development cost. To lower the ADU construction amount further, homeowners who earn less than 80% Denver Area Median Income (AMI) may qualify for the ADU Affordable Loan, a loan up to \$25,000. The WDSF+ ADU Pilot Program resources and development subsidy along with the ADU Affordable Loan make it possible for mid and low income homeowners to build an ADU.

Through the WDSF+ ADU Pilot Program, a homeowner can leverage current home equity to build an ADU and increase living space or gain a rental unit. The ADU will increase total property value, and the homeowner can build wealth and gain monthly financial benefits.

The purpose of the Pre-Qualification Application is to provide information about the WDSF+ ADU Pilot Program and determine general homeowner eligibility. Interested homeowners are asked to review the information closely and provide thorough responses. Only applicants who meet all the requirements of Part 1 should proceed to Parts 2 and 3.

- Part 1: Basic Homeowner and Property Requirements
- Part 2: Basic Financial Qualifications
- Part 3: ADU Pilot Program Terms Agreement

To be eligible to participate in the WDSF+ ADU Pilot Program, the homeowner and the property must meet certain requirements and qualifications as outlined in 'Part 1: Basic Homeowner and Property Requirements.' 'Part 2: Basic Financial Qualification' information is needed to gain a basic understanding of your financial circumstances and determine ADU financial feasibility. 'Part 3: ADU Pilot Program Terms Agreement' describes how the ADU Pilot Program creates an affordability covenant on the property for a 25 year restricted term and requests your understanding of and agreement to the terms.

Completed Pre-Qualification Applications should be delivered to West Denver Renaissance Collaborative (WDRCC) at the address below or emailed to [mywdrcc@gmail.com](mailto:mywdrcc@gmail.com). The WDSF+ team will respond to all completed applications. Eligible applicants will be notified to proceed to the next step of the ADU Pilot Program.

West Denver Renaissance Collaborative  
777 Grant Street | Denver, CO | 80203 | 720.932.3136

WDRCC  
WDSF+ Materials © 2018 WDRCC - All Rights Reserved



COUNCILWOMAN DISTRICT 1

*Amanda P. Sandoval*

DENVER CITY COUNCIL

# Contents

1. ADUs in Denver
2. District 1 Rezoning Efforts
3. Survey feedback, concerns & research





# ADUs IN DENVER

- The Denver Zoning Code (2010) has specific zone districts that allow ADUs.
- ADUs are allowed by default two-unit or multi-unit zones.
- Most property owners in single-unit areas must rezone to allow ADUs
- Nearly 30% of the city allows ADUs currently

All areas in color allow ADUs:

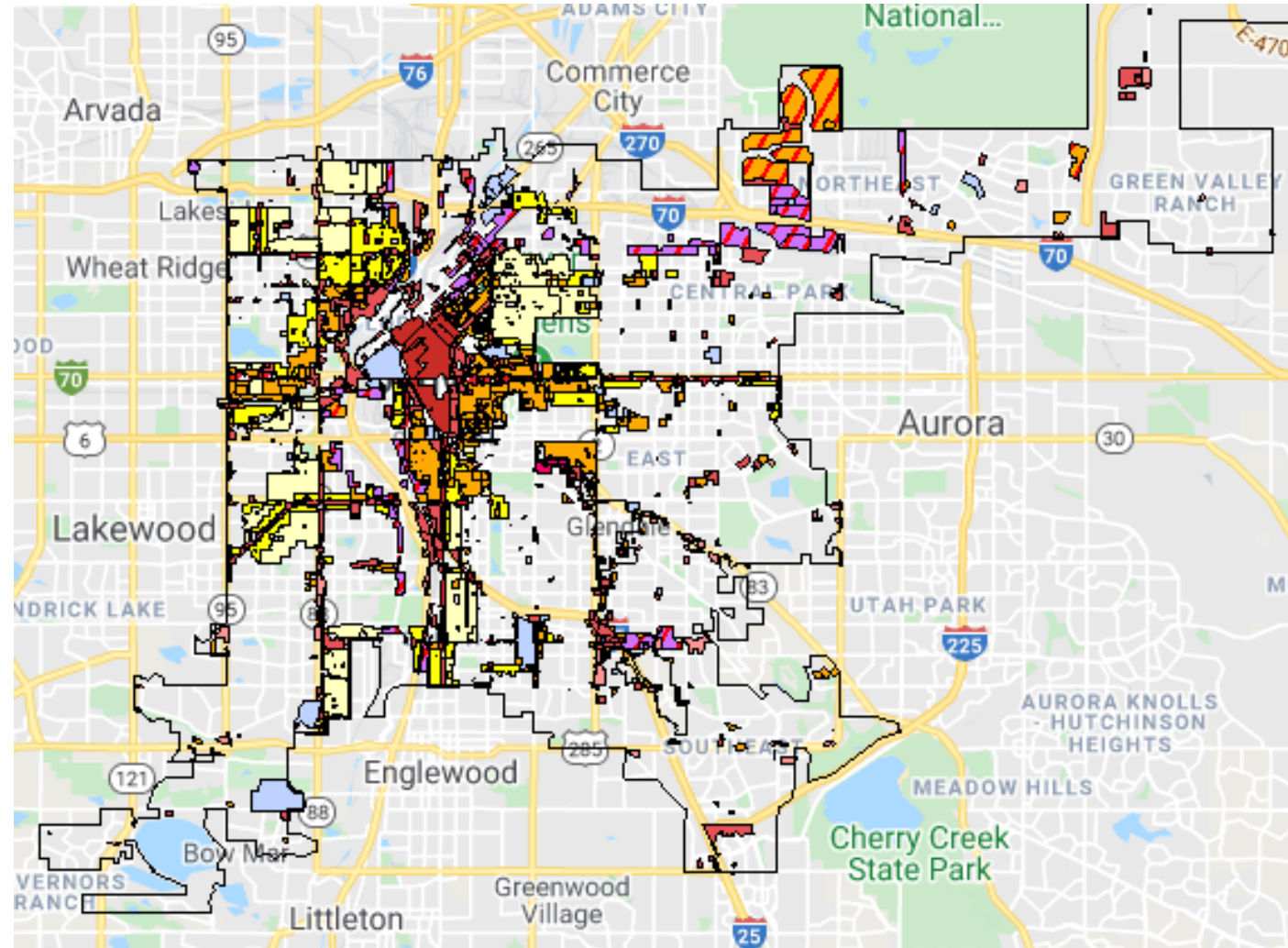



# District 1 Rezoningings

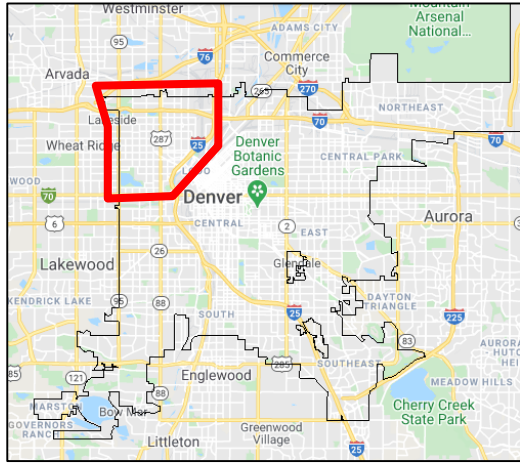

District 1

## ADUs Prohibited or Limited:

- E-SU-B
- E-SU-D
- E-SU-DX
- S-SU-D
- U-SU-A
- U-SU-B
- U-SU-C
- U-SU-C2

Total: 9,819 out of  
25,375 properties (39%)

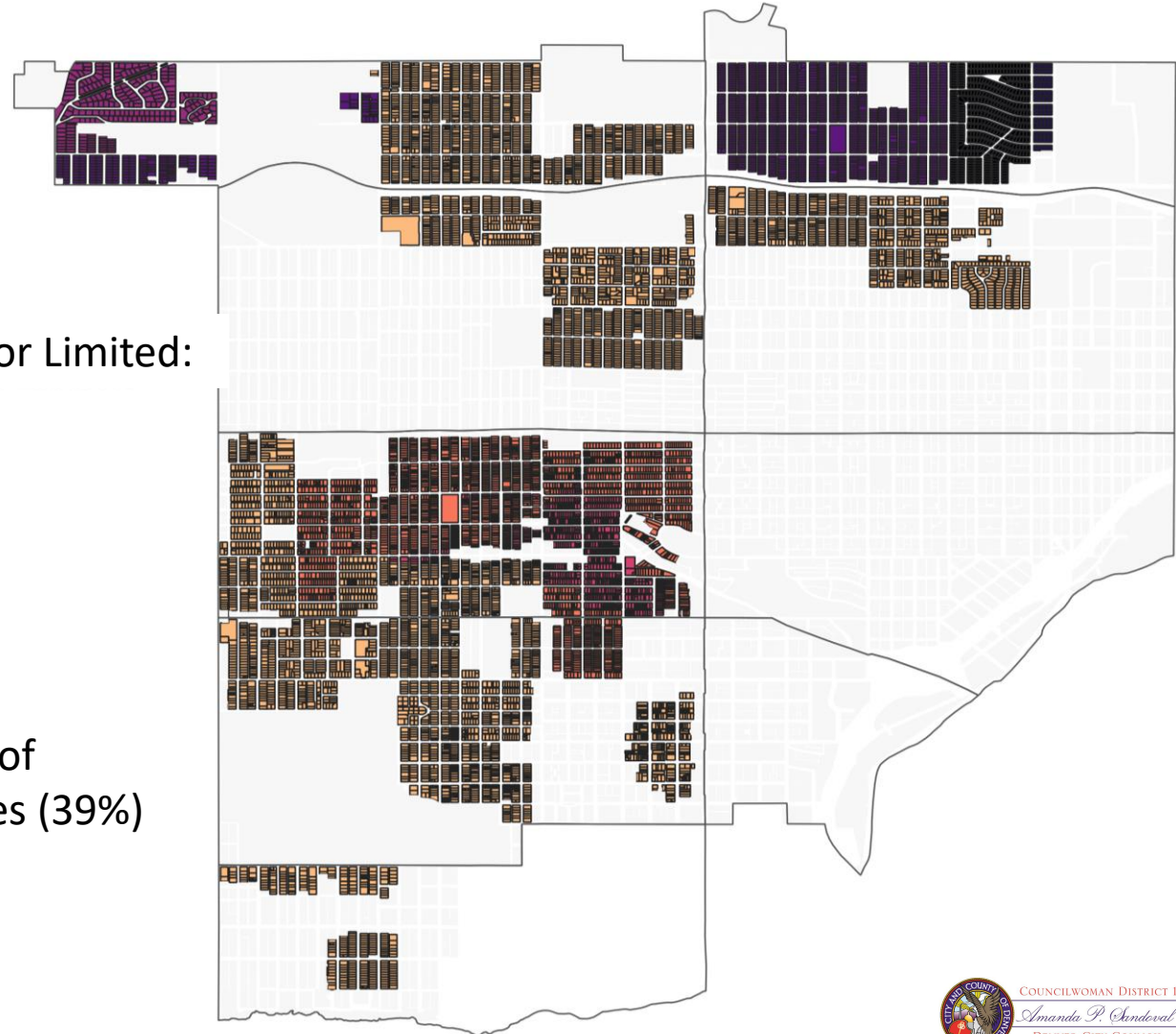





# District 1 Rezoningings

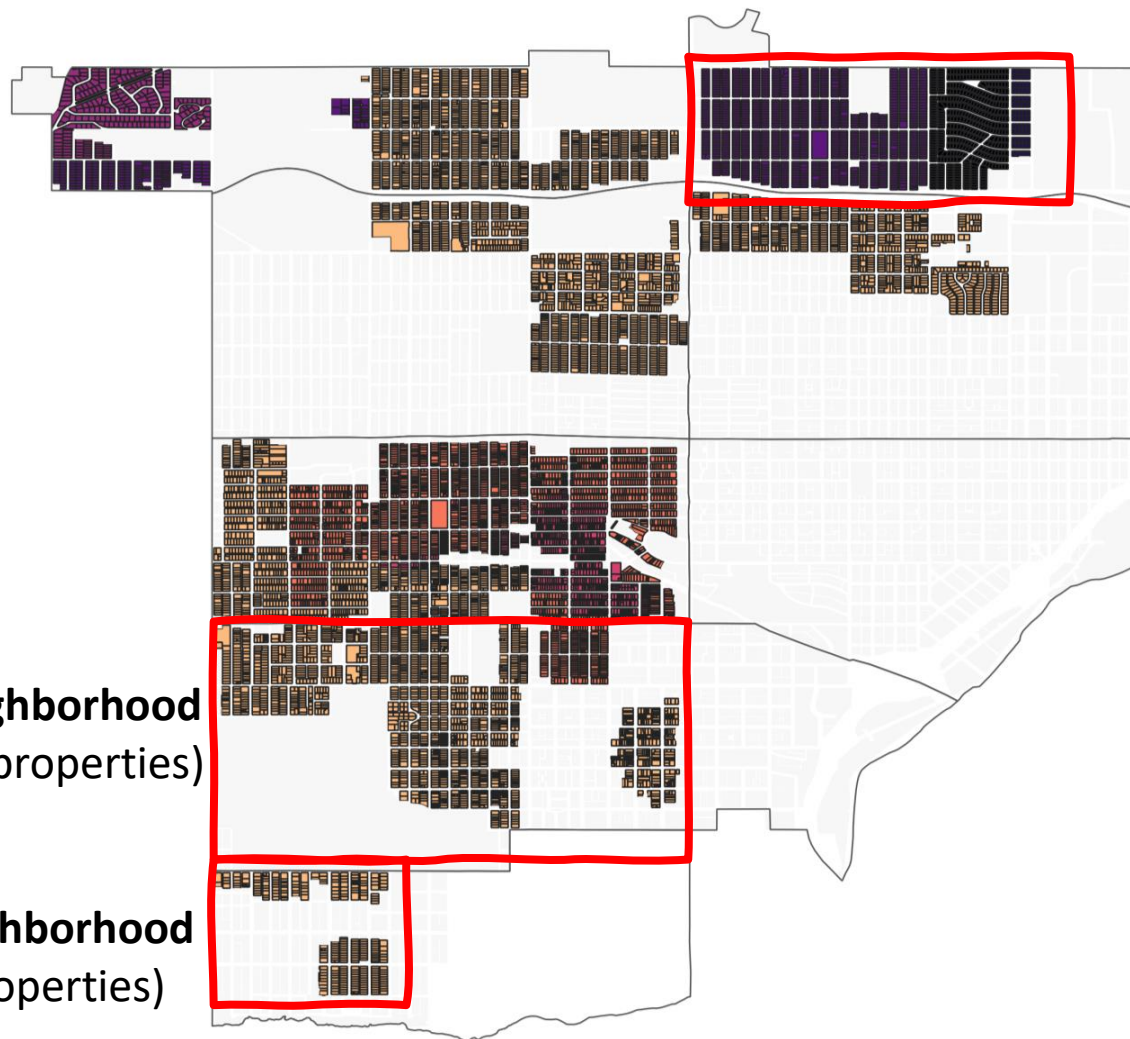

**1. Chaffee Park Neighborhood**  
*(completed, 1,410 properties)*

**2. Sloan's Lake Neighborhood**  
*(in progress, 1,742 properties)*

**3. West Colfax Neighborhood**  
*(in progress, 227 properties)*



# Community Outreach

- Town Halls
- Owner mailings
- Door flyers
- Surveys
- Neighborhood organization presentations
- Multilingual outreach

## CHAFFEE PARK NEIGHBORHOOD ASSOCIATION

### ¿Qué son los beneficios de ADUs?

- **Carácter del vecindario:** ADUs preservan el carácter existente del vecindario mientras permiten que la ciudad crezca.
- **Fortaleza de la familia:** ADUs proporcionan a la residencia existente la capacidad de albergar a miembros adicionales de la familia, permite a las generaciones mayores "envejecer en el lugar" y mantener a las familias juntas, lo que también puede ahorrar en los costos de la vida de la tercera edad o cuidado de ancios.
- **Estabilidad del vecindario:** Los ingresos adicionales de ADUs pueden ayudar a las personas a permanecer en sus hogares a pesar del aumento de los costos. Esto crea viviendas más asequibles para que las generaciones se queden en el vecindario.
- **Reducir el tráfico:** Viviendas del patio trasero promueven la seguridad de todos a través de "ojos en la calle".
- **Vitalidad del barrio:** Más personas en Chaffee Park hacen que sea más probable que las tiendas, restaurantes y otras cosas que queremos vengán a nuestras áreas comerciales existentes.

### ¿Unidades de Vivienda Accesorias (ADUs) en Chaffee Park?

La Asociación de Vecinos de Chaffee Park (Chaffee Park United Neighbors) está mirando una re zonificación para permitir las ADUs por todas partes del vecindario. Las "ADUs" son unidades de vivienda accesorias pequeñas. Una ADU se ubica en la parte trasera de una propiedad y está separada de la casa principal. Las ADUs también se conocen comúnmente como casa de huéspedes y también pequeño estudio.

### ¿Qué piensa usted?

Favor de llenar esta encuesta y compartirla con sus vecinos.

[www.chaffeePark.org](http://www.chaffeePark.org)

La encuesta está disponible en inglés y español.

### LOS HECHOS:

- Esta re zonificación lo haría patrocinado de parte de la ciudad, lo que significa que no habría ningún costo para los propietarios.
- Una ADU y la casa principal deben pertenecer al mismo dueño y vivir en una de las unidades (no permite propietarios de múltiples unidades).
- La ADU no se puede vender por separado y la propiedad debe ser más grande que la casa principal y el vecindario.
- Hay reglas que restringen el tamaño, la altura, y las materiales que se pueden usar para la ADU.
- El único cambio a esta re zonificación causaría ser permitiendo ADUs en propiedades que no están actualmente permitidas. No cambiaría nada más sobre cuánto, qué tipo de edificios se pueden construir. Por ejemplo, no desarrollo comercial.

### Aprenda Más

Asista a una de las reuniones comunitarias de Chaffee Park de ADUs con la consejera Amanda Sandoval. Se proporcionará traducción al español y cuidado de niños.

Reunion Comunitario #1  
Miércoles, November 6, 2019  
6:30 - 8:00 pm  
Beach Court Elementary  
4950 Beach Ct

Reunion Comunitario #2  
Lunes, November 11, 2019  
6:30 - 8:00 pm  
Chaffee Community Bldg  
5001 Umatilla St

Para preguntas, envíe un correo electrónico a [board@chaffeePark.org](mailto:board@chaffeePark.org) o llame al [www.chaffeePark.org/adu](http://www.chaffeePark.org/adu)



## Accessory Dwelling Units in Sloan's Lake Neighborhood? We need to hear from you!



Councilwoman Amanda Sandoval is proposing to lead a rezoning on behalf of the community to allow ADUs throughout Sloan's Lake neighborhood. ADUs are small, single dwellings located at the back of a property and separate from the main house. They are also known as granny flats, in-law units, casitas, or carriage houses. Over the past few years, many individual rezoning applications for ADUs in District 1 have come from the Sloan's Lake neighborhood. Based on this data, we believe rezoning Sloan's Lake neighborhood will save homeowners time and money.



- ### THE FACTS:
- Many rules restrict the size, height, and materials of an ADU. It must be smaller than the main house and fit in with the neighborhood.
  - An ADU and the main house must be owned by the same owner and the owner must live in one of the units (no absentee landlords).
  - The ADU can't be sold separately and the property can't be divided.
  - This rezoning would not make any other zoning change concerning what can be built in Sloan's Lake neighborhood. It would not upzone properties to allow apartment buildings, row homes or townhomes ("slot homes"), or allow commercial development in residential areas.

### We need to hear from YOU!

What do you think of allowing ADUs throughout Sloan's Lake neighborhood? Please take this survey and share it with your neighbors.

[bit.ly/sloanslakeadu](http://bit.ly/sloanslakeadu)

Survey available in English and Spanish



For questions, email [districtone@denvergov.org](mailto:districtone@denvergov.org) or call 720-337-7704



## CHAFFEE PARK NEIGHBORHOOD ASSOCIATION

### Accessory Dwelling Units in Chaffee Park?

The Chaffee Park Neighborhood Association is considering a rezoning that would allow Accessory Dwelling Units (ADU) on all parcels in the Chaffee Park Neighborhood. An ADU is a second, smaller residential building located at the back of a single-family property. ADUs are also known as mother-in-law suites, granny flats, casitas, backyard cottages, or carriage houses.

What are your thoughts?  
Please take this survey and share it with your neighbors

[www.chaffeePark.org/adu](http://www.chaffeePark.org/adu)  
Survey available in English and Spanish

**Come to an ADU Town Hall**  
Wednesday, Nov. 6th, 6:30 - 8:00 pm  
Beach Court Elementary, 4950 Beach Ct  
or  
Monday, Nov. 11th, 6:30 - 8:00 pm  
Chaffee Community Baptist Church,  
6001 Umatilla St

For questions email [board@chaffeePark.org](mailto:board@chaffeePark.org)



COUNCILWOMAN DISTRICT 1  
*Amanda P. Sandoval*  
DENVER CITY COUNCIL





# Survey Results from 720 Responses

Do You Support Rezoning to Allow ADUs?

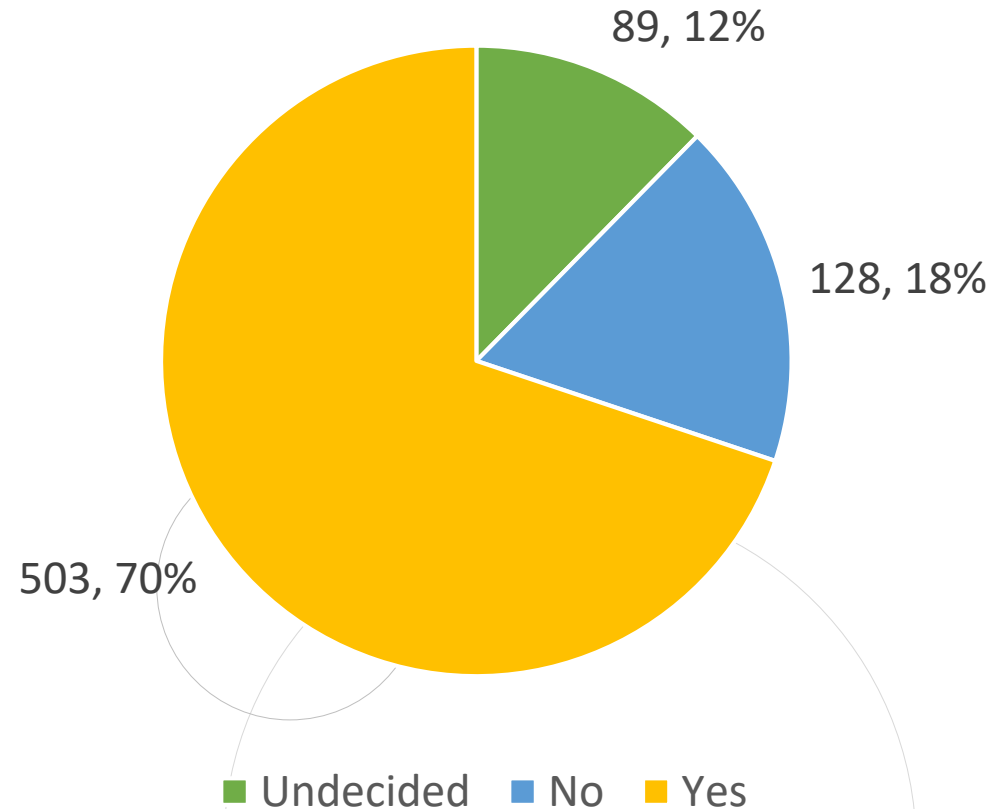



# Survey Results from 720 Responses

If the rezoning goes through, would you build an ADU?

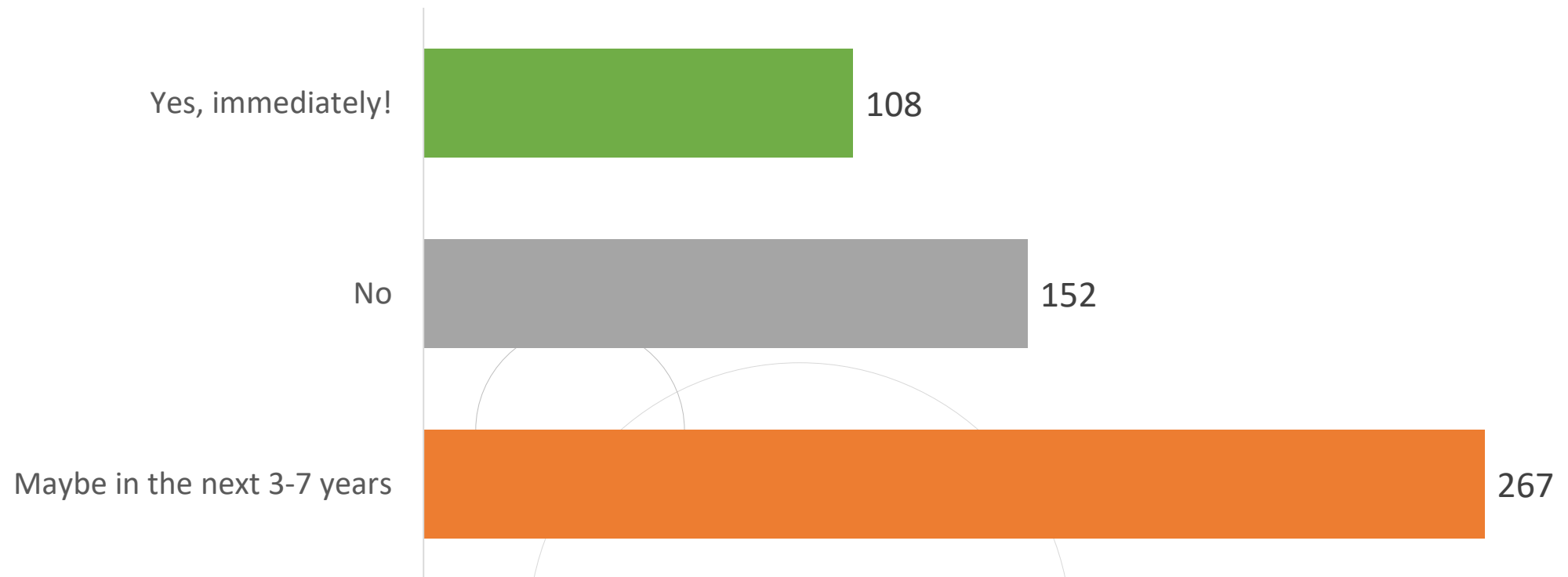





# Survey Results from 334 Responses (Sloan's Lake)

What is your PRIMARY reason for wanting to build an ADU?

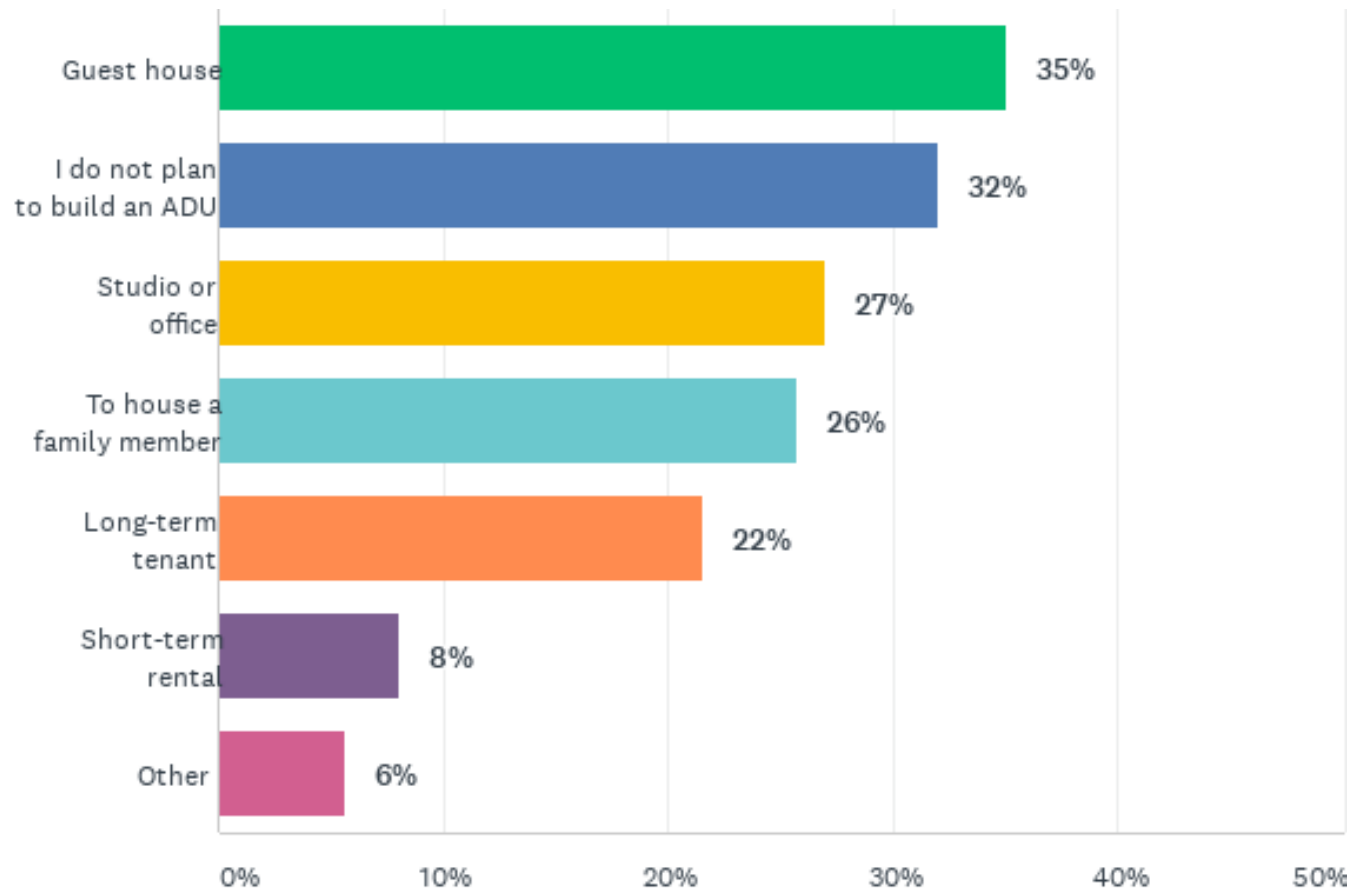

\*Multiple uses often chosen. For example, short term would be to rent to recoup costs, long term would be for family



**RMLUI 2021**  
*WESTERN PLACES | WESTERN SPACES*

# Inclusionary Housing





**RMLUI 2021**  
WESTERN PLACES | WESTERN SPACES

**Panelists:**

**Anamaria Hazard**, Dentons, Atlanta

**Stephanie Hawkinson**, Affordable  
Housing Manager, Edina MN

**Alex Radtke**, Senior Planner, Austin

**Analiese Hock**, Principal City Planner,  
Denver



# Inclusionary Zoning

## Legal Overview and a closer look at the City of Atlanta, Georgia's Policy

March 25, 2021



# What is Inclusionary Zoning?

- Requires developers to set aside a certain percentage of dwelling units at below market rates for moderate to low-income residents
  - mandatory or voluntary
  - Some jurisdictions allow developers to pay an in-lieu fee to build affordable housing
  - For sale or rental units
- Municipalities often provide incentives to developers for building affordable units
- Due to state and local law restrictions and limitations, the specifics of inclusionary zoning varies across the country

# Policy Considerations

- Alleviate concentrations of poverty and wealth
- Greater access to affordable housing for those who need it
  - Often provides housing for moderate income individuals (police, city employees, healthcare workers) who cannot afford market rate units and do not qualify for low-income assistance
- Critiques
  - Does not help those most in need
  - Decreases housing stock in jurisdictions with inclusionary zoning policies
  - Does not create equity for participants

# Key Factors for a Successful Inclusionary Zoning Program

- Strong housing market
- Mandatory
- Incentives
- Clear guidelines
- Flexible

Sturtevant, L.A. (2016). *Separating fact from fiction to design effective inclusionary housing programs*. Washington DC: Center for Housing Policy.



# City of Atlanta

## Inclusionary Zoning Policy

# State Law and Broader Context

- Rent Control
- 20 year restrictions on covenants
- The right to zone is a “police power” given to municipalities by the State with little constraint
  - State regulates zoning procedure
  - Requires a comprehensive plan
- Atlanta Housing Authority provides subsidies and vouchers for low-income residents
- Invest Atlanta (Development Authority) provides tax incentives and bonds for affordable housing
- State Fair Housing Act does not allow for expansion
- Cannot waive impact fees for affordable housing unless it is replenished by general fund

# Atlanta's Inclusionary Zoning Policy\*

- Implemented January 2018
- Applies only to the BeltLine and Westside Overlay districts
- Triggers
  - Any improvement of real property
  - 10 or more new residential dwelling units offered for rent
- All affordable units must be substantially similar in appearance and construction, proportionate in number and not isolated
- Affordable units must be “actively marketed”

FIGURE 1: INCLUSIONARY ZONING AREAS IN THE BELTLINE AND WESTSIDE ATLANTA NEIGHBORHOODS

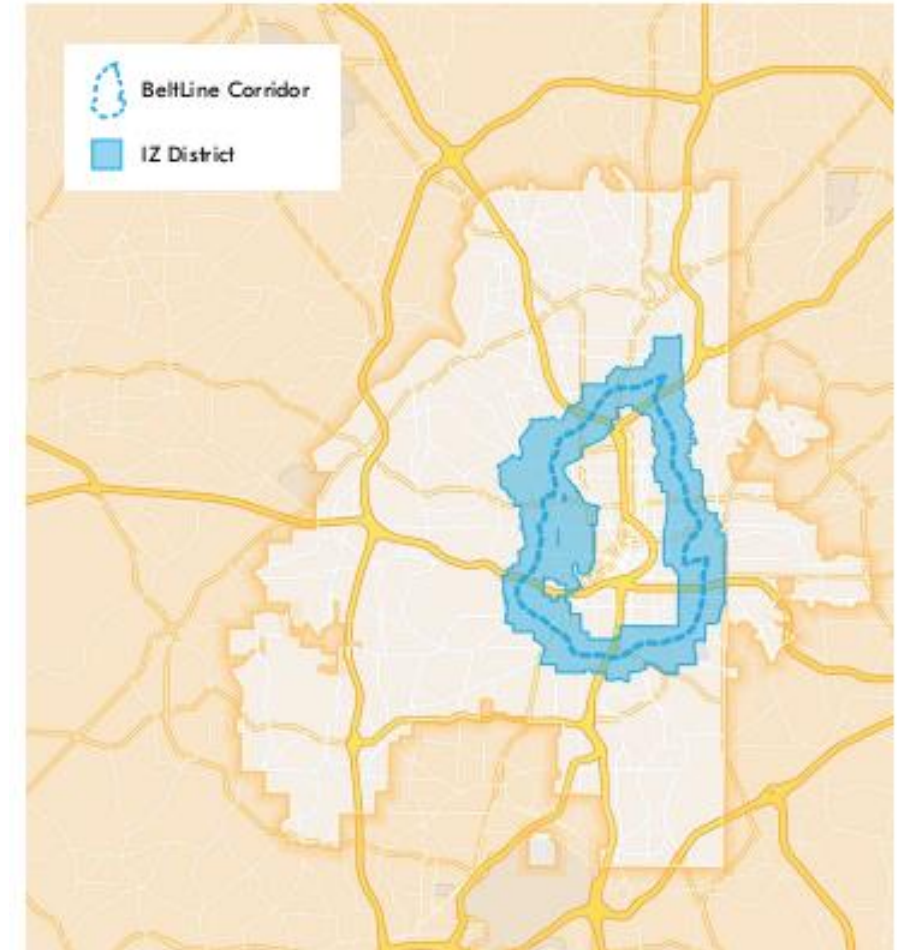

\* All pictures and data were taken from The City of Atlanta Inclusionary Zoning Report which can be accessed at [www.atlantaga.gov/iz](http://www.atlantaga.gov/iz)



# Atlanta's Inclusionary Zoning Policy\*

- On-site Requirement
  - 15% of units at 80% AMI
  - 10% of units at 60% AMI
- In lieu fee
  - Contribute to the affordable workforce housing trust fund
  - Assessed per BeltLine subarea
  - Calculated yearly to reflect current market
- 20 year affordability period enforced by a LURA
- Parking, density, and application review incentives

## TIMELINE OF IZ PROGRAM 2018-2020



FIGURE 2: RENT-BURDENED HOUSEHOLDS IN THE BELTLINE AND WESTSIDE OVERLAY NSAS, 2010-2018

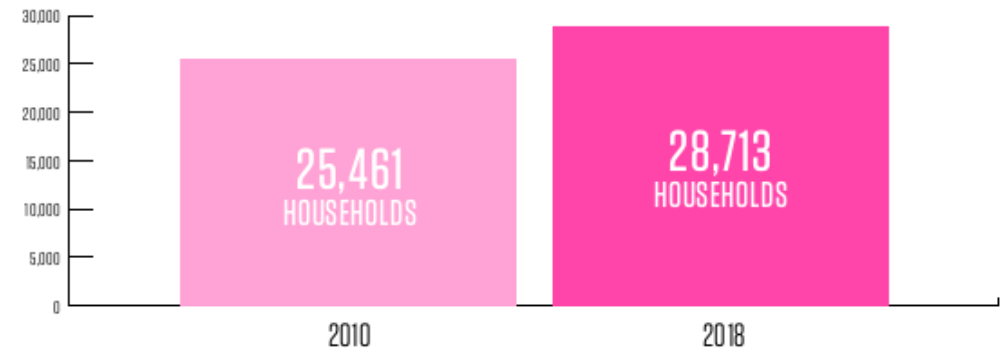

Source: ARC ACS 5-year estimates, 2014-2018.

\* All pictures and data were taken from The City of Atlanta Inclusionary Zoning Report which can be accessed at [www.atlantaga.gov/iz](http://www.atlantaga.gov/iz)

# Outcomes

## TOTAL AFFORDABLE UNITS IN PIPELINE:

**362** (AS OF DECEMBER 2020)

**TABLE 2: IZ DEVELOPMENTS AND RENT-BURDENED HOUSEHOLDS BY NSA, 2018-2020**

NSA	Number of Projects	Number of IZ Units	Rent-Burdened Households
Bankhead/Washington Park	2	34	457
Knight Park/Howell Station	1	26	74
Adair Park/Pittsburgh	2	13	725
Peoplestown	2	88	428
Choosewood Park/Englewood Manor	2	54	220
Ormewood Park	1	6	345
Old Fourth Ward/Sweet Auburn	2	14	2,488
Cabbagetown/Reynoldstown	2	67	462
English Avenue	1	21	543
Benteen Park/Blvd Heights	1	39	228

Source: ARC ACS 5-year estimates, 2014–2018.

**FIGURE 4: POVERTY RATES IN NSAs INTERSECTING THE IZ DISTRICT**

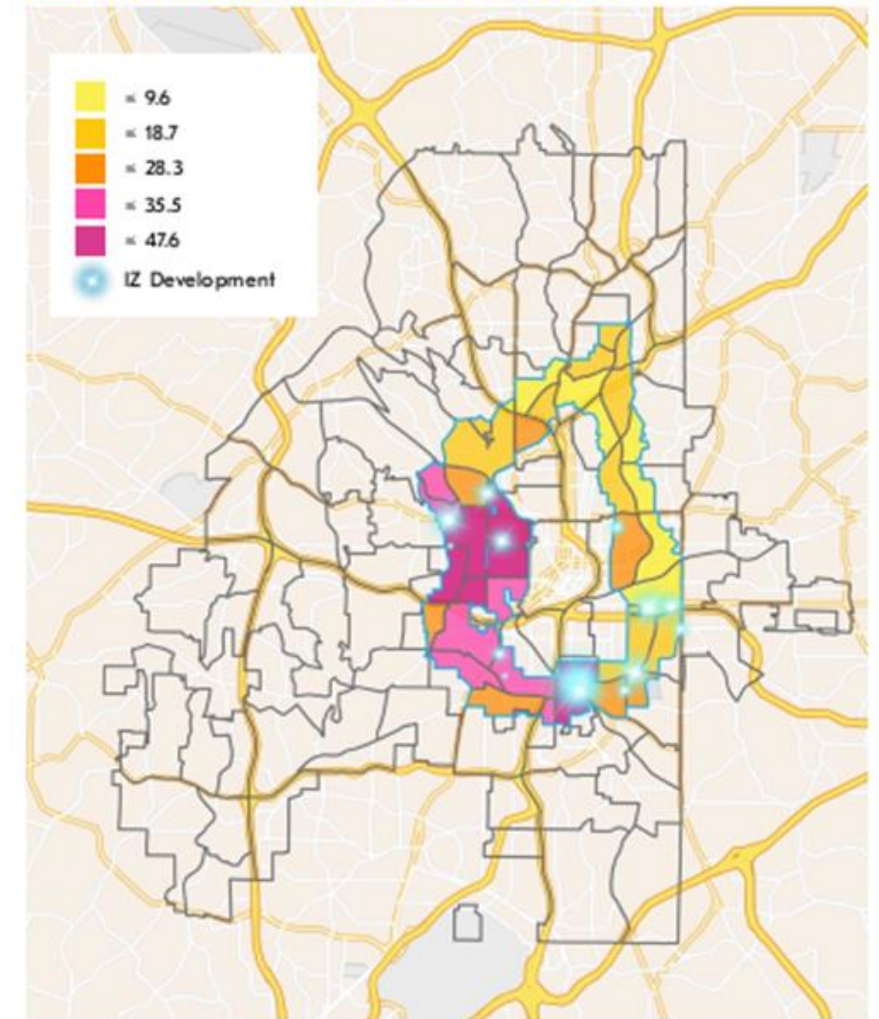

# Outcomes

- Inclusionary zoning did not result in reduced multi-family development in Atlanta

- Residents of inclusionary zoning developments had more access to recreation centers and parks but less access to MARTA and grocery stores

**TABLE 6: MULTIFAMILY PROJECT PERMITS ISSUED FOR MULTIFAMILY DEVELOPMENTS IN THE CITY OF ATLANTA, 2015–2020**

	Inside the BeltLine	Outside the BeltLine	Total
<b>2015–2017</b>	12	53	65
<b>2018–2020</b>	20	87	107
<b>Total 2015–2020</b>	32	140	172
<b>%Change 2015–2020</b>	+66.7%	+64.2%	+64.6%

Source: City of Atlanta Office of Buildings. Multifamily is defined as a building with 10 or more units with rental or for sale product. There were three condominiums permitted from 2018–2020 that are included in Table 6.

**TABLE 5: ACCESS TO PUBLIC AND PRIVATE AMENITIES FOR THE AVERAGE NSA, 2019**

	Atlanta NSAs	IZ Development NSAs	Potential IZ Development NSAs
<b>Population Density (per sq mi)</b>	4,351	5,055	5,608
<b>COA Recreation Centers</b>	0.49	0.90	0.45
<b>Park Acres</b>	55.68	25.8	42.7
<b>Grocery Stores</b>	0.78	0.90	1.15
<b>Bus Stops</b>	39	45	44
<b>MARTA Stations</b>	0.24	0.20	0.40
<b>Average Number of Businesses</b>	334	199	528

Source: City of Atlanta Department of City Planning; City of Atlanta Business License data, 2018.



# Lessons Learned

- Still not significant investment in low-poverty neighborhoods
- Consider neighborhood and community needs
- Require affordable housing around MARTA stations
- Consider policies that address layering of subsidies
- Expand program to capture for sale units

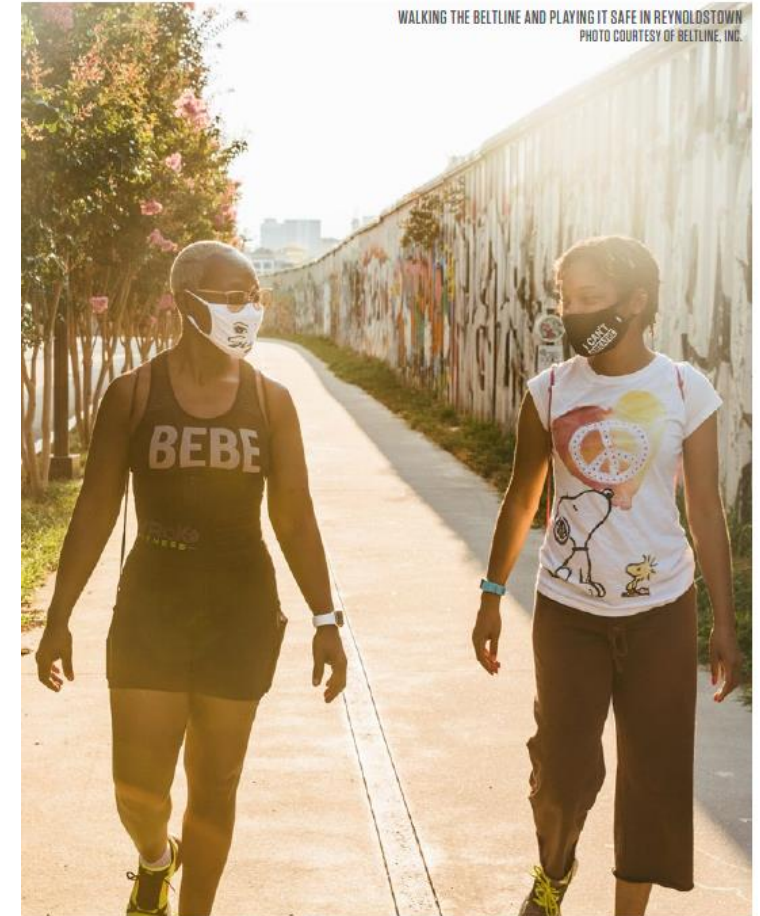

# Thank you

大成 DENTONS

Anamaria Hazard

anamaria.hazard@dentons.com

Dentons US LLP

303 Peachtree Street, NE

Suite 5300

Atlanta, GA 30308-3265

United States

---

Dentons is the world's largest law firm, delivering quality and value to clients around the globe. Dentons is a leader on the Acritas Global Elite Brand Index, a BTI Client Service 30 Award winner and recognized by prominent business and legal publications for its innovations in client service, including founding Nextlaw Labs and the Nextlaw Global Referral Network. Dentons' polycentric approach and world-class talent challenge the status quo to advance client interests in the communities in which we live and work. [www.dentons.com](http://www.dentons.com).

# New Multi-Family Affordable Housing Policy and Ordinance

Edina, Minnesota



## Broader Context



- State of Minnesota does not regulate whether a City adopts an Affordable Housing Policy or Inclusionary Zoning Ordinance.
- Edina is Statutory City meaning only allowed to pass ordinances that are specifically allowed in State statute.
- Bill proposed to limited City's ability to use PUDs.
- Metropolitan Council requires the production of new affordable housing be included in Comprehensive Plans

# Need For Affordable Housing

- Citizen Driven – Vision Edina and Quality of Life Surveys.
- Data Driven –
  - - 40,000 employees drive into Edina from elsewhere each day.
  - - Increase cost of housing has outpaced increases in income.
  - - 40% of Edina renters are cost burdened
- Mandate Driven – the Metropolitan Council established an affordable housing goal of 212 new affordable housing units by the year 2020. Between 2008 and 2015 none of those units were built. The goal for 2030 is 1,804 new units.



# Demonstration of Need

Minimum Wage Vs. Wage Required to Acquire an Average Priced House in Edina

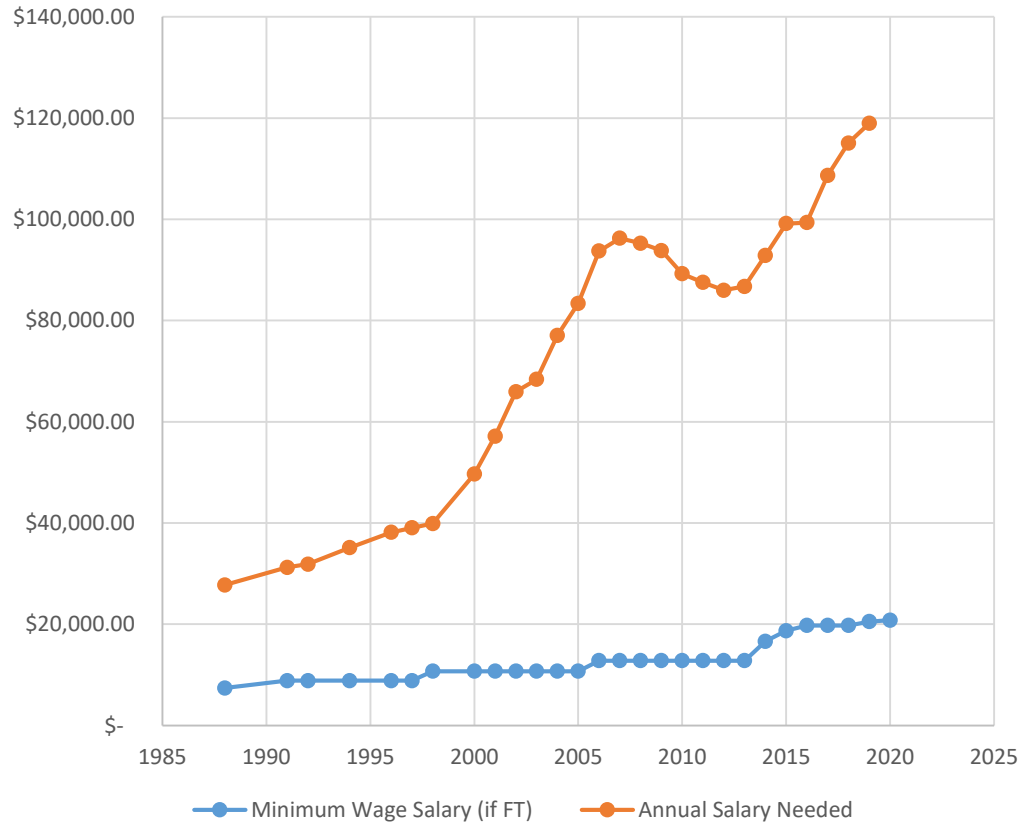

30% Average Wages in Growth Industries Vs. Average Mortgage Payment

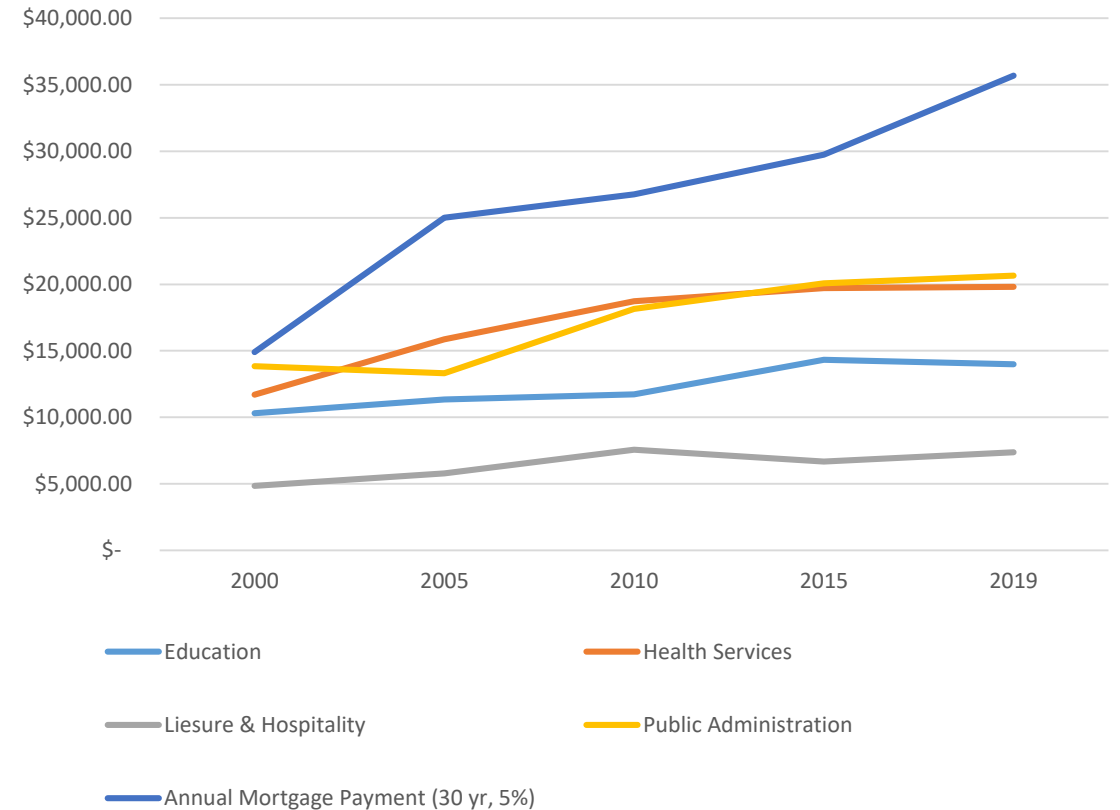



# 2018 Affordable Housing Policy

## What Triggers Policy:

1. 20 units or more.
2. Requires rezoning or Comprehensive Plan amendment OR in commercial district.
3. Receives financial assistance.
4. Developed on property owned by City.

## Requirements:

- 10% of units at 50% AMI or 20% of units at 60% AMI
- Unit mix proportional to Market Rate units mix
- Affordable period of at least 20-years (rental) or 30-years (ownership).
- Non-discrimination of Housing Choice Vouchers.
- Must submit Affirmative Fair housing Marketing Plan.
- OR Payment in Lieu - \$100,000 per 10% of units.

## Offsets:

- Density bonuses
- TIF/abatements
- Loans

# Outcomes

Between 2010-2018:

- 1,831 multifamily units approved
- 78 (4.3%) units are affordable

Since 2018:

- 658 multifamily units developed
- 192 (29.2%) are affordable

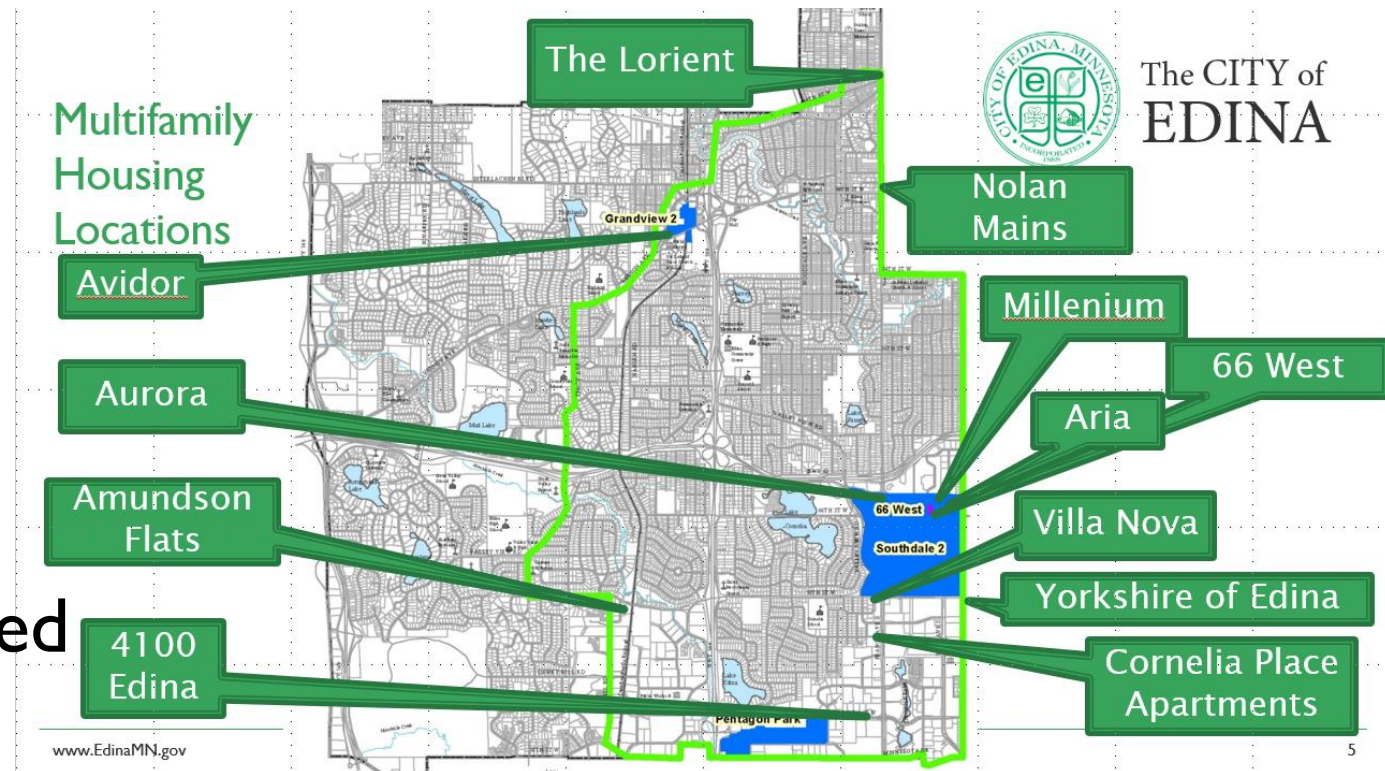

# Lessons Learned

- **CONFIRM** and **VERIFY** that developments that were to have affordable housing units have them and these units are serving the intended tenants.
- Early agreements were not prescriptive. Agreements have become increasingly defined and prescription over time.
- Add: Compliance period commences when all required units are in compliance for both rent and income.



# CITY OF AUSTIN HOUSING AND PLANNING DEPARTMENT AFFORDABILITY UNLOCKED PROGRAM



RMLUI – Inclusionary Zoning Panel  
Alex Radtke, Senior Planner  
[alex.radtke@austintexas.gov](mailto:alex.radtke@austintexas.gov)  
March 25, 2021

# INCLUSIONARY ZONING IN TEXAS

---

- Texas' Local Government Code bans mandatory inclusionary zoning with exceptions allowed for voluntary density bonus programs and homestead preservation districts
- In 2017, the state legislature also banned linkage fees as a tool to support affordable housing
- Voluntary density bonus programs are consequentially an important tool for addressing affordable housing in Austin

# PROGRAM HISTORY

---

*Affordability Unlocked's City Council Resolution was Unanimously approved by City Council on May 9, 2019*

**Purpose: To increase the number of affordable units and most effectively utilize 2018 Affordable Housing Bonds and other public funds and resources**

- Initiated amendments to create a citywide affordable housing program – applies in all commercial & residential zones, overlays, and regulating plan areas
- Included very specific direction on affordability requirements, tenant protections, redevelopment limitations, development bonuses/waivers



# WHAT IS *AFFORDABILITY UNLOCKED*?

---

- A development bonus program for housing providers.
- Offers substantial waivers of development regulations in exchange for high percentages of affordable units
- Can be paired with gap financing or other density bonuses
- Developments that meet the requirements of the Affordability Unlocked Program can be built as a permitted use on any site that is in:
  - A residential base zoning district
  - A commercial base zoning district
  - A special purpose base zoning district, except on a site designated agricultural (AG) or aviation (AV), and/or
  - A combining and overlay district.

# PROGRAM REQUIREMENTS

---

## **Type 1 Bonus:**

- **Rental Units:** Average of 60% MFI or below for 40 years
  - 20% of all units must serve 50% MFI or below
- **Owner Units:** Average of 80% MFI or below
- **Unit Size:** 25% of affordable units must have 2+ bedrooms or be used as senior or supportive housing
- **Tenant Protections:** Provide just cause eviction, tenant right to organize & SOI protections

## **Type 2 Bonus:** Meets Type 1 requirements **and** one or more of the following:

- **At least 75% of units** must be affordable
- **At least 10% of the affordable units** are deeply affordable (30% MFI = \$29,300 for a 4-person household)
- **At least 50% of affordable units** have 2+ bedrooms
- Located **within ¼-mile of Imagine Austin Corridor with transit**

# DEVELOPMENT BONUSES

---

## Waivers:

<b>Development Regulation Waived</b>	<b>City Code Section</b>
<b>Compatibility height and setback requirements (note that side setbacks required by the base zoning district are not waived)</b>	Article 10 (Compatibility Standards) and Subchapter F (Residential Design & Compatibility Standards)
<b>Floor-to-Area Ratio (FAR) limits of the base zoning district</b>	Section 25-2-492 (Site Development Regulations)
<b>Duplex regulations</b>	Section 25-2-773
<b>Minimum site area requirements of the base zoning district</b>	multiple sections
<b>Dwelling unit occupancy limits</b>	Section 25-2-511

# PROJECT PIPELINE

<b>Applications Received *As of 9/3/2020</b>	<b>46</b>
<b>Certified</b>	<b>26</b>
<b>Cancelled/No response</b>	<b>5</b>
<b>Certified Type 1</b>	<b>10</b>
<b>Certified Type 2</b>	<b>16</b>
<b>Certified Ownership % (# of units)</b>	<b>31% (8)</b>
<b>Certified Rental % (# of units)</b>	<b>69% (18)</b>
<b>Total # Certified Units (affordable / market)</b>	<b>2,721 (2,337 / 384)</b>

<b>District</b>	<b># of Certified Projects</b>	<b>%</b>
<b>1</b>	<b>5</b>	<b>19%</b>
<b>2</b>	<b>3</b>	<b>12%</b>
<b>3</b>	<b>6</b>	<b>23%</b>
<b>4</b>	<b>5</b>	<b>19%</b>
<b>5</b>	<b>3</b>	<b>12%</b>
<b>6</b>	<b>0</b>	<b>0%</b>
<b>7</b>	<b>2</b>	<b>8%</b>
<b>8</b>	<b>0</b>	<b>0%</b>
<b>9</b>	<b>1</b>	<b>4%</b>
<b>10</b>	<b>1</b>	<b>4%</b>

**70% of certified project applications indicated participation in LIHTC or RHDA/OHDA programs for funding.**

**65% of certified projects are also SMART – certified.**

**The A on Lamppost became the first certified project to break ground on July 22<sup>nd</sup>, 2020.**



# Denver's Inclusionary and Related Programs

*RMULI – 3/25/2021*



# The Colorado Legal Context

## **1981** Colorado Ban on Rent Control

- Barred municipalities from “enacting any resolution or ordinance that would control rent on private residential real property or private residential housing units” via CRS § 38-12-301

## **2000** Telluride Decision

- Determined that inclusionary housing/zoning policies on rental housing would be considered a form of rent control. Therefore, inclusionary policies can only apply to for-sale housing.

## **2021** HB-1117 Local Government Authority Promote Affordable Housing Units

- Would enable for inclusionary housing policies to apply to rental housing

# History of Inclusionary Policies in Denver

**2000 - 2001** Site specific negotiated outcomes (interim tool)

**2001 – 2002** Inclusionary Housing Ordinance 

**2017- Current** Linkage Fee 

**2018 - Current** Incentive Pilot Programs 

*2019 - Current Negotiated Voluntary Housing Agreements*

*2021 – Current Expanding Housing Affordability*

# Inclusionary Housing Ordinance (IHO)

**2002 -2016** IHO was the primary tool to providing affordable home ownership in Denver

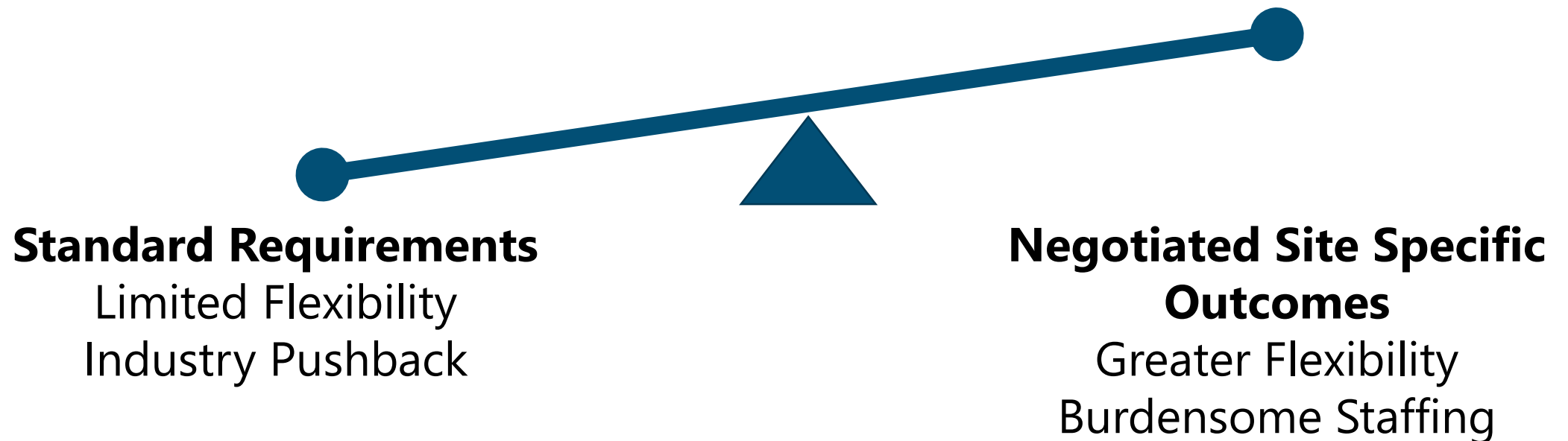



# Inclusionary Housing Ordinance (IHO)

- **Trigger:** For-sale housing of 30 units or more
- **Requirements:**
  - High-Cost Structures: 10% of total units, serving households earning 50% to 95% AMI, 30-year affordability
  - Standard Structures: 10% of total units, serving households earning 50% to 80% AMI, 30-year affordability

# Inclusionary Housing Ordinance (IHO)

- **Alternative Compliance:**

- Building additional units at one or more sites in the same or an adjoining statistical neighborhood
- Building additional units at one or more sites within five-tenths (.5) miles of a light rail or commuter rail station
- Contributing to the Special Revenue Fund an amount equal to fifty percent (50%) of the price per affordable unit not provided

# Inclusionary Housing Ordinance (IHO)

- **Rebates/Incentives for On-Site Development**
  - \$5,000 per unit up to \$250,000 per development, per year
  - Funded through projects subject to the ordinance that paid the fee-in-lieu
  - Density incentives (very minimal, e.g., Downtown 0.4 FAR)
  - Parking Reduction of 20%

# Inclusionary Housing Ordinance (IHO)

## Outcomes:

- **2,028** for sale units
- **\$7.6M** from Cash-In-Lieu

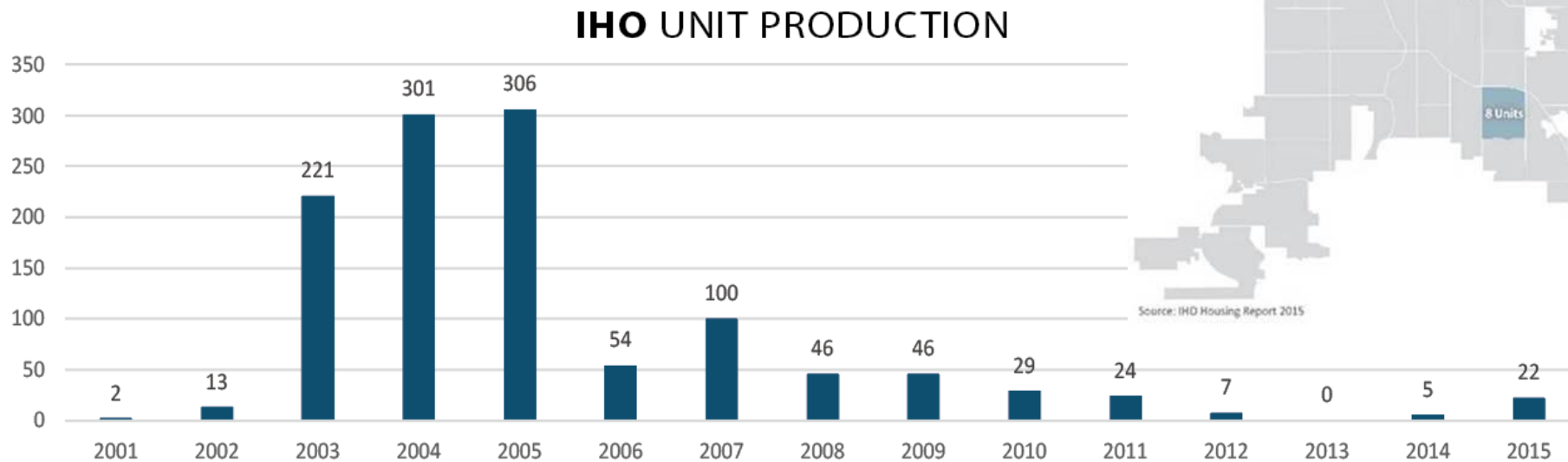

Source: IHO Housing Report 2015

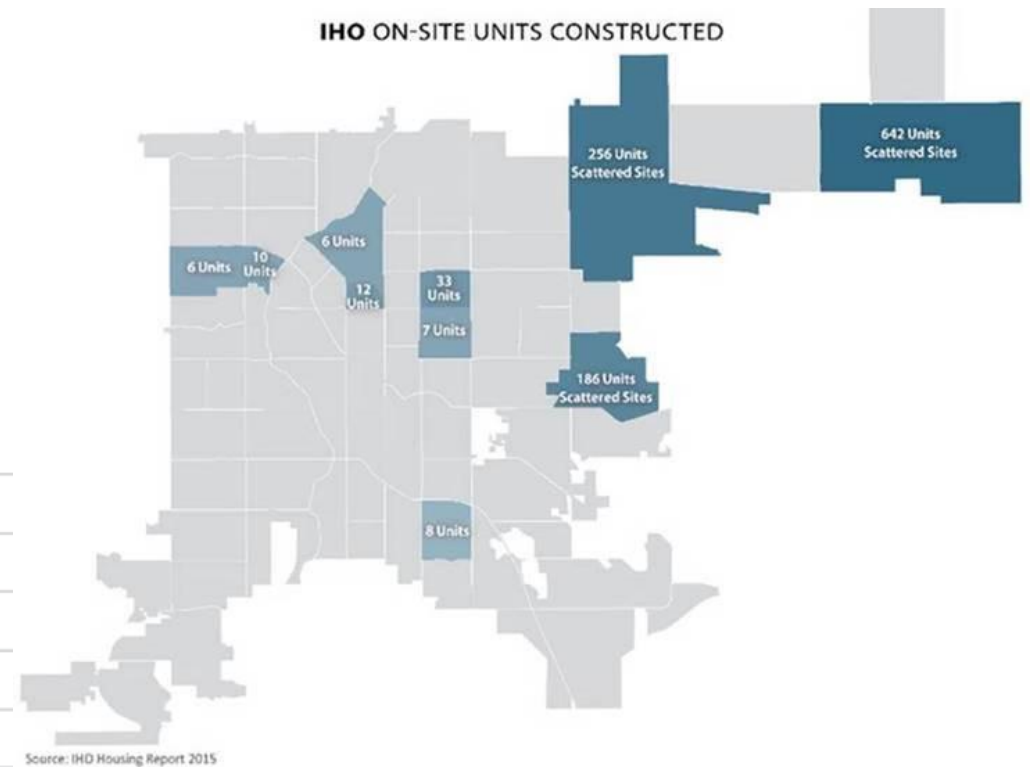



# Inclusionary Housing Ordinance (IHO)

## Shortcomings:

- Low production rates compared to overall city growth
  - Impacts of the great recession
  - Construction defects legislation
  - Applicability size 30+ units
- 185 foreclosures
  - Response and changes to the ordinance in 2013/2014 included:
    - Required Homeownership Counseling
    - Expanded Income Eligibility
    - Hardship exemptions changed enabling more flexibility for people to rent the unit if needed (e.g., military service, divorce, job lay-offs, etc.)

# IHO: Enforcement and Compliance

## 2018 Auditor Report

- Headline: “The Office of Economic Development’s Lack of Proper Implementation and Enforcement of Regulations Is Not Ensuring Affordability of Housing”
  - Incorrect calculations of resale prices
  - Income eligibility is property verified to ensure monthly housing payments are affordable.
  - Inaccurate collection of fees from developers and over dispersion of incentive payments
  - Inaccurate data in compliance tracking

# Linkage Fee

Pivot in City policy/priority from **unit production** to **fee generation** that applies to all new development

Nexus study (legally justified fee) **\$9 – 119** per/sf



Financial feasibility study found **\$7** per/sf was financially feasible



Current fees **\$0.43** to **\$1.83** per/sf

# 38<sup>th</sup> and Blake Incentive Pilot Program

**TOD Area with strong market demand**

Adopted in 2018

Established base (3-8 stories) and incentive heights (6-16 stories)

**7** developments used the height incentive

Produced **95** affordable units and **1,843** market rate units

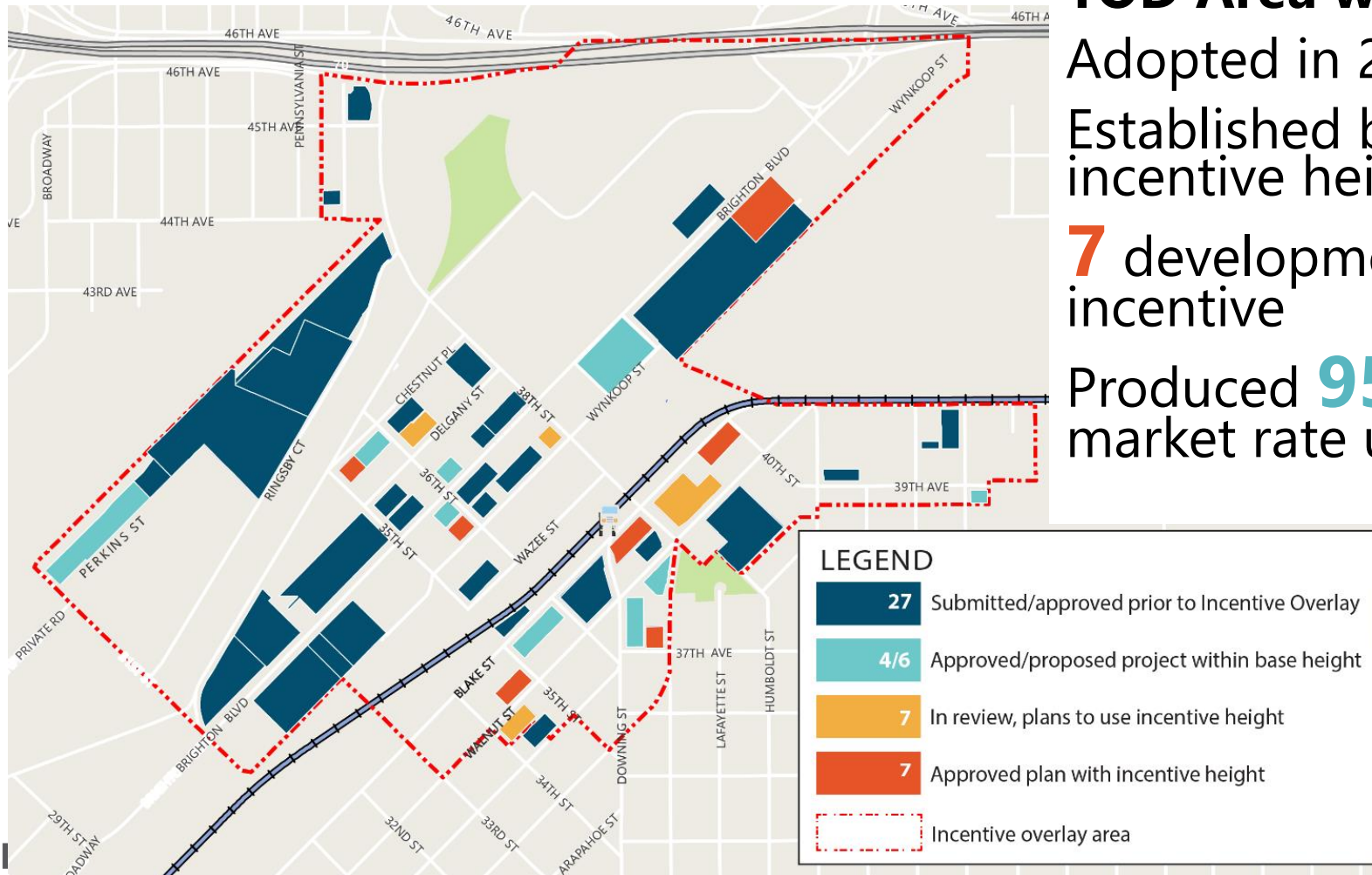



# Lessons Learned

- **Compliance** is critical
- Citywide programs need to be **calibrated to sub-market costs** (e.g., land values, zoning entitlement, housing need)
- **Fees-in-lieu** ought to reflect the cost of developing affordable units
- A **variety of incentives** are offered and complementary to mandatory requirements to achieve greater levels of affordability
  - Incentives need to align with market demand
- Affordability **longevity is key**
  - Citywide policy now 60-years (2019)
  - Preservation ordinance (2019)
- **Clarity and predictability** is necessary for both the development industry and residents

# Looking Forward

- Housing needs are growing
  - Housing costs are rising at 2X the rate of wages
  - Low-income and communities of color are being displaced
- Existing tools are leading to gaps in housing affordability for moderate wage households and employment sectors
  - Public funds prioritize 0-60% AMI
  - Market-rate housing provides 120% AMI +
- Implementing our citywide plans to create an equitable, affordable and inclusive Denver

# Looking Forward

- **Expanding Housing Affordability** Project will now involve:
  - a citywide zoning incentive for affordable housing
  - an update to the city's linkage fee
  - preparation for potential changes to state law on inclusionary housing

More details and resources online at:

[www.denvergov.org/affordabilityincentive](http://www.denvergov.org/affordabilityincentive)

[Analiese.hock@denvergov.org](mailto:Analiese.hock@denvergov.org)